

ODEN AT

High Current System



User's manual

User's Manual

for

High Current System

ODEN AT

NOTICE OF COPYRIGHT & PROPRIETARY RIGHTS

© 2002, Programma Electric AB. All rights reserved.

The contents of this document are the property of Programma Electric AB. No part of this work may be reproduced or transmitted in any form or by any means, except as permitted in written license agreement with Programma Electric AB.

Programma Electric AB has made every reasonable attempt to ensure the completeness and accuracy of this document. However, the information contained in this document is subject to change without notice, and does not represent a commitment on the part of Programma Electric AB.

TRADEMARK NOTICES

Programma® is a registered trademark of Programma Electric AB.

All other brand and product names mentioned in this document are trademarks or registered trademarks of their respective companies.

Programma Electric AB is certified according to ISO 9001.

Programma Electric AB
Eldarvägen 4
SE-187 75 TÄBY
Sweden

Tel +46 8 510 195 00
Fax +46 8 510 195 95



Contents

1 Safety precautions	9	5.3 MEMORY and APPLICATION menu options	25
1.1 You must read the following safety precautions thoroughly	9	MEMORY.	25
Precaution levels	9	APPLICATION	26
1.2 Precaution level – DANGER	9	6 How to install Oden AT	27
1.3 Precaution level – WARNING	10	6.1 Safety	27
1.3 Precaution level – Important	11	6.2 Loading Oden AT onto a carriage	27
2 Introduction	13	6.3 Connecting the test object and the current units to each other.	28
2.1 General	13	6.4 Series connection (output HIGH I)	29
Current can be generated in many ways:.	13	6.5 Parallel connection (output HIGH I)	30
The measurement section contains/provides (among other things):.	13	6.6 Low-current output (output 0-30V/60V) .	30
2.2 Fields of application	14	6.7 Connecting current units to the control unit.	31
2.3 Reservations	15	6.8 Grounding Oden AT.	31
3 Control panel	17	6.9 Connecting Oden AT to the mains	32
3.1 Oden AT control panel.	17	6.10 Mains power supply	32
MAINS block	17	Mains voltage	32
CURRENT ADJUST block	18	Input Current.	32
VOLTMETER AND A-METER 2 block	18	Mains cable and connectors	32
OUTPUT block	18	6.11 Current cables and conductors	33
AUX block	18	Available cable sets	33
STOP INPUT block	18	Standard multi-cable sets	33
MENU block	20	6.12 How to arrange the cable sets.	36
DISPLAY block	20	Minimising impedance in cables	36
4 Display	21	6.13 How To Arrange Bars.	38
4.1 The display	21	To get equal current from all current units. 38	
Directional indicators	21	7 How to use Oden AT	39
When special applications are activated .	21	7.1 How to generate current	39
5 Menu options	23	7.2 Rules of thumb when generating current	40
5.1 General	23	7.3 Setting the desired current	40
5.2 AMMETER, V/A METER and SYSTEM menu options	23	Low currents:	40
A-METER 1	24	High currents:	40
SYSTEM	25	7.4 Setting times for limited-time generation (MAX TIME)	41

7.5 Continuous current generation	41	8.3 Measuring the polarity of a current transformer	61
7.6 Getting maximum current from Oden AT .	42	8.4 Measuring the resistances of breakers and electrical connections (microhmmeter testing).	62
7.7 Improving the resolution of current settings.	42	8.5 Testing a direct acting automatic recloser Time test.	63
7.8 Generating pulse trains	43	8.6 Testing a sectionalizer	64
7.9 Holding (freezing) measured values	43	8.7 Testing a ground grid	65
7.10 Measuring phase angle and polarity. . .	44	9 Troubleshooting.....	67
7.11 Measuring Z, P, R, X, S, Q and power factor ($\cos \varphi$).	45	9.1 General	67
7.12 Reading maximum current at an operation.	45	Problem: No current is sent out from Oden AT	67
7.13 Measuring operating limits	46	Problem: Not possible to switch on Oden AT. The display is dark.	67
Method 1: Normal injection; gradually increase in current.	46	Problem: Generation stops immediately or after half a cycle.	67
Method 2: Manually controlled momentary injection	46	Problem: Generation does not stop when the breaker opens.	67
Method 3: Limited-time generation . . .	47	Problem: Unexpected value on Ammeter 1.	67
7.14 Measuring tripping/operation times. . .	47	Problem: The miniature circuit breaker F2 or the mains supply fuse trips.	67
7.15 Instantaneous trip unit measurement .	48	9.2 Error messages	68
7.16 Selecting Oden AT configuration and current cables	49	Current units	68
Introduction	49	Message: "Type X curr unit not installed"	68
Available systems	49	Message: "Curr units have diff settings"	68
Test circuit impedance limits the current	49	Message: "Curr units are of diff types"	68
7.17 How to succeed in selecting a suitable ODEN AT system	50	9.3 Measurement errors.	69
Distance to the test object	50	Problem: No reading on voltmeter and ammeter 2.	69
Impedance of the test object	50	Problem: Time " 0.000s " is displayed but generation continues.	69
Procedure	50	Problem: " — A or — V" is displayed.	69
Current calculation example	51	Problem: " — OFA or OFV" is displayed.	69
7.18 Examples	53	Problem: "AMP2=0A AMP1=0A" is displayed.	69
Example 1, Current Transformer.	53	Problem: "**** A" is displayed.	69
Example 2, Low Voltage Circuit Breaker .	54	Problem: Unexpectedly long trip-time while testing instantaneous trip on a circuit breaker.	69
Example 3, Low Voltage Circuit Breaker .	54		
Form 1	55		
Form 2	57		
8 Application examples	59		
8.1 Testing a low-voltage breaker	59		
8.2 Testing the ratio of a current transformer	60		

10 Calibration	71	Oden AT/1S (400 V)	84
10.1 General	71	Oden AT/2S (400 V)	84
10.2 Calibration of offset	71	Oden AT/3S (400 V)	84
10.3 Calibration of scale factor, ammeter 1 .	72	Oden AT/1X (400 V)	84
Scale factor, range LOW	72	Oden AT/2X (400 V)	85
Scale factor, range HIGH	72	Oden AT/3X (400 V)	85
10.4 Scale factor for the I/30-function.	72	Oden AT/1H (400 V)	85
10.5 Calibration of scale factor, ammeter 2 .	73	Oden AT/2H (400 V)	86
Scale factor, range 0 – 2 A	73	Oden AT/3H (400V)	86
Scale factor, range 0 – 20 A	73	11.5 Load curves, Oden AT systems	
10.6 Calibration of scale factor, voltmeter . .	73	for 400 V.	87
Scale factor, range 0 – 0.2 V	73	OUTPUT HIGH I, Oden AT systems	
Scale factor, ranges 0 – 2 V, 0 – 20 V		for 400 V 50/60 Hz and 480 V 60 Hz . .	87
and 0 – 200 V	73	OUTPUT HIGH I, Oden AT systems	
10.7 Resetting to preset (standardized)		for 400 V	88
calibration values	74	OUTPUT 0 – 30 V/60 V, Oden AT systems	
Performing a reset	74	for 400 V 50 Hz	90
11 Specifications	75	OUTPUT 0 – 30 V/60 V, Oden AT systems	
11.1 General	75	for 400 V 50 Hz	91
11.2 Output specifications for 240 V Oden AT		11.6 Output specifications for 480 V Oden AT	
systems at 50 Hz.	76	systems at 60 Hz.	92
Oden AT/1S (240 V)	76	Oden AT/1S (480 V 60 Hz)	92
Oden AT/2S (240 V)	76	Oden AT/2S (480 V 60 Hz)	92
Oden AT/3S (240 V)	76	Oden AT/3S (480 V 60 Hz)	92
Oden AT/1X (240 V)	76	Oden AT/1X (480 V 60 Hz)	92
Oden AT/2X (240 V)	76	Oden AT/2X (480 V 60 Hz)	93
Oden AT/3X (240 V)	77	Oden AT/3X (480 V 60 Hz)	93
Oden AT/1H (240 V)	77	Oden AT/1H (480 V 60 Hz)	93
Oden AT/2H (240 V)	77	Oden AT/2H (480 V 60 Hz)	94
Oden AT/3H (240 V)	78	Oden AT/3H (480 V 60 Hz)	94
11.3 Load curves, Oden AT systems		11.7 Load curves, Oden AT systems	
for 240 V.	79	for 480 V 60 Hz.	95
OUTPUT HIGH I, Oden AT systems		11.8 Ammeter 1	98
for 240 V at 50/60 Hz operation	79	11.9 Stop input	99
OUTPUT HIGH I, Oden AT systems		Appendix 1.....	101
for 240 V	80	A1.1 Transferring test data to a PC or	
OUTPUT 0-30V/60V, Oden AT systems for		a printer	101
240 V at 50/60 Hz operation	82	A1.2 Setting up the connection	101
OUTPUT 0-30V/60V, Oden AT systems for		How to connect via Win 9X Hyper Terminal .	102
240 V at 50 Hz operation	83	How to connect via Win 2000 Hyper	
11.4 Output specifications for 400 V Oden AT		Terminal	103
systems at 50 Hz.	84	A1.3 Transfers in " NORMAL USE "	104

A1.4 Transfers in applications " TEST RECLOSER " and " SECTIONALIZER "	105
Appendix 2	107
A2.1 Resistance measurement accuracy . .	107
Factors that influence accuracy	107
Accuracy estimation	107
Index	109

1 Safety precautions

1.1 You must read the following safety precautions thoroughly

- Always follow the local safety regulations that apply to work with high-voltage equipment.
- Make certain that all personnel who work with Oden AT have been trained in its use and that all applicable safety precautions are taken.
- Read and comply with the following instructions as well as the warnings and instructions on the Oden AT control panel.

Precaution levels

The manual uses three safety flags to indicate different levels of danger.

All Danger, Warning and Important notes must be followed for your safety. The safety messages will be in the following formats:



Means you may risk possible severe bodily harm or loss of life, and damage to the test object and/or test equipment.



Means you may risk possible bodily harm and damage to the test object and/or test equipment.

Important

Means you risk damage to the test object and/or the test equipment.

1.2 Precaution level – DANGER

Here are the general precautions for level Danger. You must also read and follow the additional safety precautions in each appropriate section of the manual.



DANGER
The voltages and currents that are generated by Oden AT can cause serious injury.



DANGER
When you are changing the connections make sure that current not can be generated accidentally. Disconnect the mains supply or switch the miniature breaker F2 to the 0-position.



DANGER
Dangerous voltages can develop at exposed connectors if the equipment malfunctions.

DANGER
The voltage at the output terminals can be dangerous. Especially when units are connected in series.

DANGER
Never use a high-current output while simultaneously using a low-current output!

DANGER
Making microhmmeter tests on a breaker. Make certain that the breaker is closed and grounded on one side before connecting Oden AT to the breaker.

DANGER
When testing current transformer. Dangerous voltages can appear in the secondary circuits if they are open.

DANGER
A current unit connected to other current units must also be connected to the control unit. Otherwise dangerous voltages might appear in the connector on the control cable, and the current unit might be damaged by current flowing backwards.

**DANGER**

This equipment can be used only in electrical systems with single Ground. User must verify before connecting this unit to power, that High Voltage Ground and Low Voltage Protective Ground create a single protective ground with no measurable voltage potential existing between these ground systems. If a voltage potential is found between the ground systems please consult local safety regulations.

1.3 Precaution level – WARNING

Here are the general precautions for level Warning. You must also read and follow the additional safety precautions in each appropriate section of the manual..

**WARNING**

All current units used must also be connected to the control unit. Otherwise the current unit might be damaged.

**WARNING**

Always use a grounded mains cable to connect the control unit to the mains. Always ground Oden AT using a separate ground cable

**WARNING**

The current output terminals and connecting points can be hot after generation of high current.

**WARNING**

Never switch between the 30 and 60 V settings when Oden AT is generating.

**WARNING**

When loading Oden AT on a carriage. To prevent tip-over, the current units must be loaded onto the carriage from bottom up.

**WARNING**

The carriage is primarily intended for transportation but may also be used when testing. The carriage must then be secured to prevent tip over. It should withstand a horizontal force of 250 N (N = Newton, approx. 56 lbs of force) in any direction applied anywhere to the equipment.

If securing is not possible stack the units on a flat surface that can support the load of the units. Make sure that the stack will withstand a horizontal force of 250 N in any direction applied anywhere to the equipment.

**WARNING**

The steel brackets mounted on the carriage are only intended for keeping the Oden AT units in place during transportation. They are not dimensioned to carry the weight of a current unit. A current unit should always rest either on the loading pallet or on top of another current unit.

**WARNING**

Never try to service Oden AT yourself. If you open the casings of the current units or control unit you may be exposed to dangerously high voltages.

1.3 Precaution level – Important

Here are the general precautions for level Important. You must also read and follow the additional Important notes in each appropriate section of the manual.

Important!

Make certain that mains outlet and its fuses and all cables/wiring have sufficient current-carrying capacity, i.e. suitable ratings.

Never connect Oden AT to a mains voltage other than that specified on the data plates (nameplate) on the control unit and the current units.

Do not connect units that are of different types to each other. Only connect type S units to type S units, type H to type H etc.

Disconnect Oden AT from the mains voltage:

When not in use

When it is not attended

During electrical storms (lightning)

Before cleaning

Clean the Oden AT with a moist rag.

Do not use liquid or aerosol cleaning agents.

Do not spill water or other liquids onto Oden AT.

If you need to return your Oden AT, please use either the original crate or one of equivalent strength. Otherwise there is risk for transportation damages.

2 Introduction

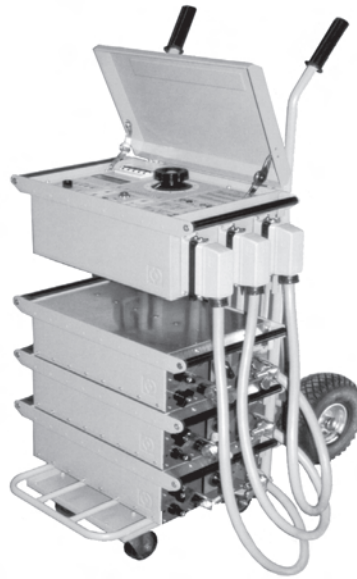

2.1 General

Oden AT is intended for use in high-voltage substations and industrial environments, for laboratories and testing purposes. Oden AT consists of a control unit equipped with a control panel and can be connected to one, two or three current units mounted on a carriage. All units are portable and easy to assemble and connect. Assembly and connection are explained in chapter 6 "How to install Oden AT".

Since Oden AT can incorporate up to three current units, which can be connected to each other in series or in parallel, AC current can be generated in a number of current/voltage combinations. Oden AT is available in models for 240 V and 400 V mains voltages. There is also a model for operation on 480 V 60 Hz only.

Oden AT is designed to generate short-duration current, and is protected from overheating. Under special circumstances, Oden AT can generate up to 21,900 amperes.

The current units come in three models: type S, type H and type X. Each current unit contains a number of toroidal transformers whose common secondary side consists of a busbar connected to the HIGH I output. This output can deliver very high currents. For data, see chapter 11 "Specifications".

A current unit of type X has, in addition to its regular high-current output, a low-current output (0-30V/60V) consisting of two extra windings that each can provide 30 V. Using a switch the windings

can be connected either in series or in parallel to the 0-30V/60V output, providing either a 30 V or a 60 V output. For data, see chapter 11 "Specifications".

The control unit controls the current output (generation) from the current units and is equipped with sophisticated measurement facilities. When current is first generated for a load, the control unit can sense the phase angle and adapt subsequent generation operations so that they all start at the current's zero-cross-over points. This ensures minimized DC offset in connection with starting.

Current can be generated in many ways:

- Continuously.
- During a preset maximum time.
- As long as you press a button.
- Until an external signal activates the stop input.
- At a lower current ($I/30$) to avoid unnecessary heating of the object being tested while the current is being adjusted.
- In pulses (both pulse duration and between-pulse pause are user-definable).

The measurement section contains/provides (among other things):

- Timer.
- Digital ammeter (true RMS).

- An additional channel for measuring a voltage or a second current.
- Direct display of the turns ratio of a current transformer.
- Provisions for measuring phase angle Z, P, R, X, S, Q and power factor ($\cos\phi$).
- Currents and voltages expressed (if so desired) as percentages of nominal values.
- Fast-acting hold function. Measured values can be frozen in response to a signal arriving at the stop input and/or when the current is interrupted.

In addition to its normal working mode, there are special Oden AT settings supporting the following types of testing:

- Microhm measurement (DC resistance is calculated).
- Testing of direct acting automatic reclosers.
- Testing of sectionalizers.

Even though Oden AT features outstanding versatility, it is very easy to use because:

- You can start generation whenever desired.
- You can repeat a measurement by simply pressing a button. It is not necessary to clear the display first.
- You can save different settings for Oden AT in ten different memories.

2.2 Fields of application

Oden AT is primarily intended for:

- Testing of protective relay equipment (primary injection testing).
- Testing of breakers with overcurrent tripping.
- Conducting ratio tests on current transformers.
- Conducting polarity tests on current transformers.

Other fields of application include:

- Tests requiring high currents.
- Measuring the resistance of breakers with normal operating current.
- Testing direct-acting automatic reclosers.
- Testing sectionalizers.
- Testing ground grids.

2.3 Reservations

When set at maximum current, Oden AT is designed only for temporary (short-duration) current generation. Do not use Oden AT for long-term generation at full current. See the product specifications in chapter 11.

3 Control panel

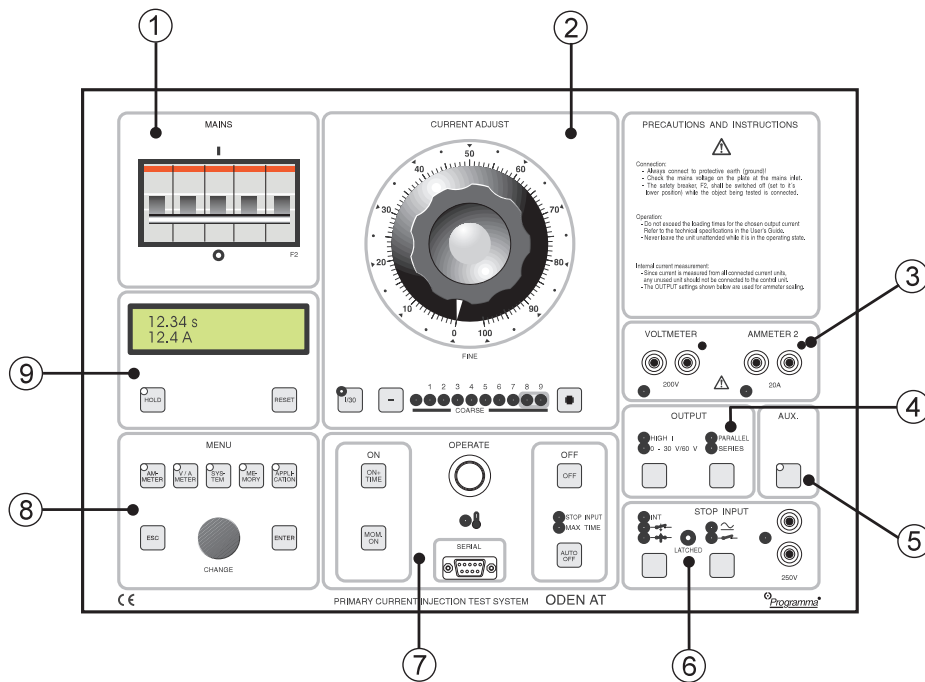

3.1 Oden AT control panel

This chapter presents an overview of the Oden AT control panel. The control panel is divided into a number of blocks:

- 1 MAINS
- 2 CURRENT ADJUST
- 3 VOLTMETER AND A-METER
- 4 OUTPUT
- 5 AUX
- 6 STOP INPUT
- 7 OPERATE
- 8 MENU
- 9 DISPLAY

More detailed descriptions of the display and the menu options appear in chapter 4 "Display" and chapter 5 "Menu options".

MAINS block

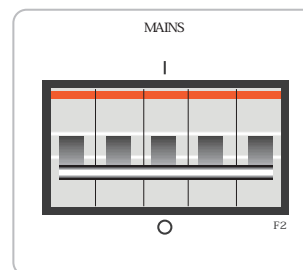

This block contains a miniature circuit breaker (F2) connected to the current generation circuitry. It can be operated manually and used as a disconnecter to prevent unintentional generation. The mains ON/OFF switch is on the left-hand side of the casing. Beside the mains ON/OFF switch is a fuse (F1) used for the control unit's internal power supply.

CURRENT ADJUST block

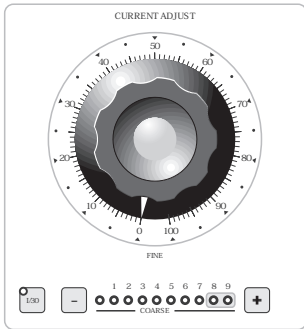

In this block you set (adjust) the generated current. The <FINE> knob is used to make fine adjustments. The <+> or <-> buttons are used to make coarse adjustments. The step 8 and 9 on the COARSE LED-scale are used only in combination with current units of type H.

The I/30 option enables you to make the settings at a reduced current, only 1/30 of the real test current, see section 7.3 "Setting the desired current". The settings are approximate and work best on linear loads.

VOLTMETER AND A-METER 2 block

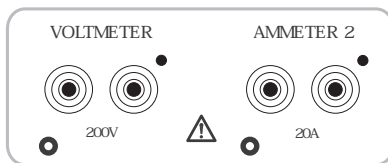

In this block you make the connections needed to measure a voltage or a second current. This is useful when (for example) you want to measure phase angles, polarity or a the turns ratio of a current transformer. You can make your settings using the <V/A METER> menu option in the MENU block.

An indicator lamp lights up to indicate whether you have activated the voltmeter or Oden AT's ammeter 2 (A-METER 2).



WARNING

The VOLTMETER and AMMETER 2 inputs are internally connected.

OUTPUT block

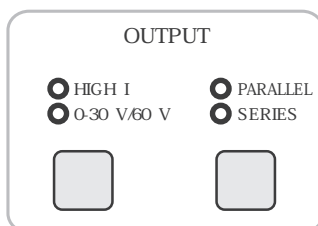

In this block you specify which current output you

are using and how the current units are connected to each other.

Important!

The settings in this block must be made before current generation starts. Check carefully to see that what you have specified is correct - if not, the values presented on the display will be incorrect.

HIGH I:

Select this if you are using the high-current output.

0-30/60 V:

Select this if you are using the low-current output (0-30/60V) on a current unit of type X.

PARALLEL:

Select this if the current units are connected in parallel or if you have only one current unit connected.

SERIES:

Select this if the current units are connected in series.

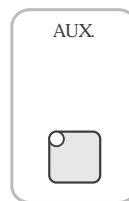

AUX block

This block is not used.

STOP INPUT block

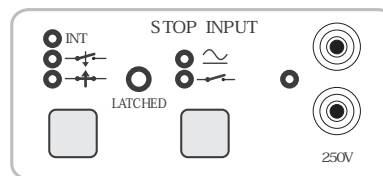

In this block you enter the stop condition. When this condition is met, the current generation and timer stops and the measured value can be frozen (held).

Internal detection INT

Hold/Stop takes place when the current is interrupted by the object being tested.

Voltage mode

The input responds to application or interruption of voltage.

Contact mode

The input responds to the opening or closing of a contact.

The input responds to application of voltage or the closing of a contact.

⚡ The input responds to the interruption of voltage or the opening of a contact.

The status lamp adjacent to the connection sockets lights up:

- In the voltage mode — if voltage is present.
- In the contact mode — if the contact is closed.

When the preset stop condition is met the LATCHED lamp lights up. Resetting takes place automatically when you start a new generation or when you press the <RESET> button in the DISPLAY block.

You can set the stop condition in a number of different ways. You can use the following combinations:

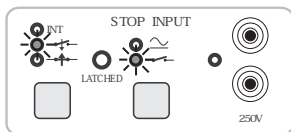

Oden AT is set to respond to the closing of an external contact.

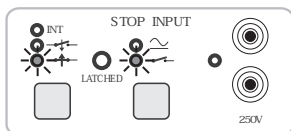

Oden AT is set to respond to the opening of an external contact.

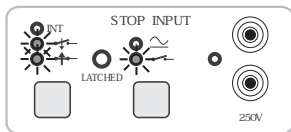

Oden AT is set to respond to the opening or closing of an external contact.

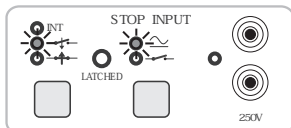

Oden AT is set to respond to the application of a voltage.

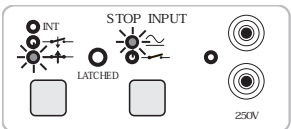

Oden AT is set to respond to the interruption of a voltage.

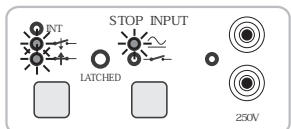

Oden AT is set to respond to the application of a voltage or the interruption of a voltage.

OPERATE block

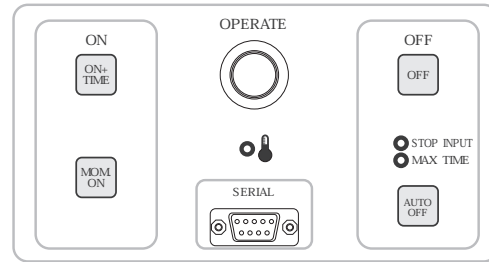

Here you can start and stop current generation.

OPERATE: This lamp lights up when current is generated.

Temperature alarm:

This lamp will light up if the temperature rises too high and Oden AT risks becoming overheated.

<ON+TIME>: Starts current generation. When generation starts the timer is instantaneously reset and restarted.

<MOM ON>: Current generation starts and continues as long as you press the button.

<OFF>: Stops current generation. Use this button to turn off current generation.

<AUTO OFF>: Activates the automatic shutoff-function. Oden AT will automatically stop generating current after a specified period of time. Press the button until the MAX TIME lamp lights up, and enter the maximum generation time using the <CHANGE> knob.

This button can also be used to activate the automatic shutoff when a stop condition is met. Press the button until the STOP INPUT lamp lights up, and enter the desired stop condition in the STOP INPUT block.

SERIAL: The SERIAL port (RS232C-port) is used when you want to transfer test results from Oden AT to a PC or a printer. See appendix 1.inter. See appendix 1.

MENU block

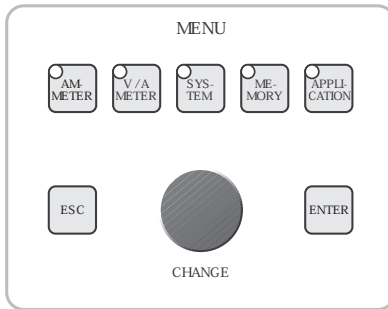

In this block you can select special functions and change the settings for the measuring instruments.

Press the button to the desired menu option. Use the <CHANGE> knob to select a function or alter a value. Press the <ENTER> button to confirm your choice and/or proceed to the next level. Press the <ESC> button to cancel and/or go back to the previous level.

- <CHANGE> Knob used for selecting and stepping in the menus.
- <ENTER> Press this to confirm a choice. Also used for initiating data dump via the serial port, see appendix 1.
- <ESC> Press this button to cancel or return to the previous level in a menu. Also used to activate R, Z, X, φ (phase angle), P, S, Q and power factor ($\cos\varphi$) measurements or to read the maximum current during an operation.

The different menu options are described in greater detail in chapter 5 "Menu options".

<AMMETER>

In this menu option can you select the range for ammeter 1 (A-METER 1, measuring the generated current), and specify whether the measured values are to be expressed a) in amperes, b) as percentages of nominal current or c) as ratios. See section 5.2.

<V/A METER>

In this menu option can you choose between using the voltmeter or the ammeter 2 (A-METER 2, measures a second current), select their ranges and how the values should be expressed. In this menu option you can also set the system to measure the turns ratio of a current transformer. See section 5.2.

<SYSTEM>

In this menu option can you specify a) the time unit to be used by the timer, b) whether or not filtering is to be used for unstable measured values, and c) the amount of delay for the automatic shutoff in accordance with the preset stop condition. In addition

you can select the language that will be used in the display and make the desired entries for calibration. See section 5.2.

<MEMORY>

This menu option enables you to recall or save settings for Oden AT in 10 memories. See section 5.3.

<APPLICATION>

In this menu option can you set Oden AT for the following applications:

- Normal use.
- Microhm measurement.
- Testing of a direct acting automatic recloser.
- Testing of a sectionalizer.
- Generation of a pulse train.

The APPLICATION menu option is described further in section 5.3. The different applications are described in detail in chapter 7 "How to use Oden AT" and in chapter 8 "Application examples".

DISPLAY block

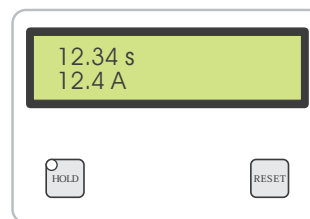

This block contains the display which presents times, currents or voltages as well as messages and menus. Chapter 4 "Display" describes the display and its functions in greater detail.

You can change the settings for the timer, the ammeters and the voltmeter via the MENU block if you do not want to use the default settings.

<HOLD>

Pressing this button freezes (holds) the measured values. When the lamp in the <HOLD> button glows steadily it indicates that the HOLD function is active. Freezing takes place a) when the stop condition is met or b) when generation is shut off, whereupon the lamp in the <HOLD> button starts to flash. The frozen value disappears as soon as you start a new generation or press the <RESET> button.

<RESET>

This button is used to clear (reset) the values shown on the display.

4 Display

4.1 The display

The display:

- Presents measured values.
- Presents Oden AT's settings.
- Guides you by providing helpful messages, warnings and prompts.
- Helps you scroll through menu options by displaying directional indicators.

The display is divided into 4 areas. Normal use:

Time	
Ammeter 1	Ammeter 2 / voltmeter

Example:

1.234 s	
750 A	3.123 V

By pressing the ESC key; Z, ϕ (phase angle) & Z, P, R, X, S, Q, power factor ($\cos\phi$) or max I¹⁾ will appear in the upper area of the display.

¹⁾ Max I is the highest current value that was generated (minimum time 100 ms) during the injection.

Example:

	4.164 mΩ Z
750 A	3.123 V

"O.F." (Overflow) in an area means that the value is too high.

"- - -" in a field means that it is impossible to present a value. The reason can be too low measurement signal or that it is impossible to calculate a value.

If you press <ENTER> the measured values will be dumped via the serial (RS-232) port, see appendix 1

for details.

Directional indicators

The directional indicators that appear on the display show which direction you can scroll using the <CHANGE> knob. There are three types of directional markers:

- ▲ You can scroll upwards
- ▼ You can scroll downwards
- ◆ You can scroll both up and down

When special applications are activated

When a special application is activated this is indicated in the upper right corner.

Example:

Application "TEST RECLOSER

1.234 s	RECL.
750 A	

See further the descriptions of the application modes, chapter 8 "Application examples".

5 Menu options

5.1 General

This chapter explains the menu options available in the MENU block on the control panel and the settings that you can make there. All settings appear on the display.

You can only select a menu option while Oden AT is in the OFF state (i.e. not generating).

There are three ways to exit from a menu option:

- Press the button of the most recently selected menu option a second time.
- Press <ON+TIME>.
- Press <RESET>.w

5.2 AMMETER, V/A METER and SYSTEM menu options

You can set Oden AT's first ammeter (A-METER 1) in the <AMMETER> menu option. In the <V/A METER> menu option you can set Oden AT's second ammeter (A-METER 2) and Oden AT's voltmeter. In the <SYSTEM> menu option you can set the timer, select the desired language for use on the display, and make certain other settings. The menu options are described in detail below.

How to set values:

An example of how the display can appear for the <AMMETER> menu option appears below. The top line (the menu heading) shows what is to be set. The second line (right-justified) shows the actual setting. You can use the <CHANGE>-knob to scroll through the different menu headings. The directional indicators show the direction or directions in which you can scroll.

Example:



- You can scroll upwards.

Select the desired menu heading (RANGE for example) and press <ENTER>. The value will appear between flashing arrow-heads < >:



You can now change the setting (to the low A range for example) using the <CHANGE> knob.

Press <ENTER> to confirm your choice. You can press the <ESC> button to leave the field without changing it or to return to the previous level.

A-METER 1

In this menu option you can make settings for Oden AT's first ammeter (A-METER 1). You can select the range and the unit in which the reading is to be expressed (amperes, percentage of nominal current or as a ratio). In addition, you can specify the nominal current itself.

The available settings are listed below.

Ammeter 1		
Menu	Settings	Description
Range	Auto	Range is selected automatically
	Low	Low range is selected ¹⁾
	High	High range is selected ¹⁾
Unit	Ampere	Current reading in Ampere
	% of In	Current reading as percentage of nominal current
	I1/I2	Current reading as the ratio of generated current (I1) to current measured by AM-METER 2 (I2)
Nominal Current	Value in A	Here you can set the value of the nominal current
¹⁾ The value for range Low or High depends on your configuration and on which output you are using, see section 11.6		

V/A METER

In this menu option you can select to use the voltmeter or the second ammeter (A-METER 2). You can also modify the settings for the instruments. You can select the range and the unit in which the reading is to be expressed (volts/amperes or percentage of nominal voltage/current). In addition, you can specify the nominal current/voltage itself and have the turns ratio for a current transformer displayed.

First in the menu you have to select between A-METER 2 or VOLTMETER. Select the desired instrument by pressing <ENTER>. The instrument will be activated and you can now modify its settings.

The available settings are listed in the table below.

V/A Meter		
Menu	Settings	Description
A-Meter 2, Range	Auto	Range is selected automatically.
	0 – 2 A	0 – 2 A range is selected.
	0 – 20 A	0 – 20 A range is selected.
A-Meter 2, Unit	Ampere	Current reading in Ampere.
	% of In	Current reading as percentage of nominal current
	CT ratio	Ratio for a current transformer is presented as XXXX/In (XXXX=I1x Im/I2). The value for I2 is set to In x (factor). I1 is multiplied with the same factor
A-Meter 2, Nom I	Value in A	Here you can set the value of the nominal current
V-Meter, Range	Auto	Range is selected automatically
	0 – 0.2 V	0 – 0.2 V range is selected
	0 – 2 V	0 – 2 V range is selected
	0 – 20 V	0 – 20 V range is selected
	0 – 200 V	0 – 200 V range is selected

SYSTEM

In this menu option you can a) select the unit in which the timer results will be expressed, b) activate DC-measurement function and c) specify the delay time for the automatic shutoff (AUTO OFF) function. You can also activate the Auto-Dump function and select the language that will be used on the display. Finally you can set the INT level and the threshold for detection that the generated current is interrupted.

The available settings are listed in the table below.

System		
Menu	Settings	Description
Timer	Seconds	Time displayed in seconds.
	Cycles	Time displayed in number of mains voltage cycles.
	hh:mm	Time displayed in hours, minutes and seconds. Seconds are displayed up to 1 min.
DC- Measurement	On/Off	Oden AT can be set to measure DC-current (A-meter 1 and 2) and DC-voltage (V-meter). See note.
OFF Delay	Cycles	Specify the number of mains voltage cycles which the automatic shut-off is to be delayed (in accordance with the preset stop condition).
Auto-Dump	On/Off	Oden At can be set to automatically dump test data to a PC when the generation is stopped. See Appendix 1.
Language	English French German Spanish Swedish	Language used on the display.
INT-level	Value in 0.7 or 2.1% of range	The threshold for detecting that the generation has been interrupted can be changed. See section 11.6 Ammeter 1 ranges.

Note: The DC- measurement function is used when Oden AT is used together with a rectifier box. A-meter 1 and 2 shows rectified average value and voltmeter shows average value.



Tip!

Try higher INT-level if trip-time is unexpectedly long and try lower INT-level if trip time is unexpectedly short.

5.3 MEMORY and APPLICATION menu options

In the <MEMORY> menu option, you can store present settings in one of Oden AT's 10 memories, or recall previously stored settings. In the <APPLICATION> menu option, you can change Oden AT's mode of operation to support certain applications, like testing direct acting automatic reclosers or generate pulse trains (pulse-pause-pulse-pause etc.). These menu options are described in the table below.

Setting values

You make all selections and settings using the <CHANGE>-knob. You confirm your entries by pressing <ENTER>, whereupon you advance further into the menu. The directional indicators show you the direction (or directions) in which you can scroll. You can return to the previous level by pressing the <ESC> button.

You select the item you want to change with the <CHANGE> knob. Check to see that it is bracketed by arrow-heads (< >) and then press <ENTER>. The arrow-head brackets will start to flash to indicate that you can change the item using the <CHANGE> knob. When you are finished, press <ENTER> to confirm your entry.

MEMORY

You can save your regular Oden AT settings in this menu option. Moreover you can, for example, prepare settings in advance and save them so that they can be recalled whenever desired. Oden AT has ten memories numbered 0-9 where you can save settings. The memories retain their contents even when power to the Oden AT is turned off.

When you start Oden AT, the settings saved in memory number 0 are loaded automatically. This means that if you want a specific set of settings to be used the next time you turn Oden AT on, you can save them in memory 0 before turning Oden AT off. There is one additional memory called the standard memory in which the factory settings are kept, these factory settings cannot be changed.

The available settings are listed in the table below.

Memory		
Menu	Settings	Description
RECALL or SAVE	RECALL 0 - 9	Recalls settings from a specific memory.
	RECALL Standard	Recals factory settings.
	SAVE 0 - 9	Saves settings in specified memory.

Recalling settings from a memory

1. Press the <MEMORY>-button
2. Turn the <CHANGE>-knob until "RECALL" appears on the display and press <ENTER>.
3. Turn the <CHANGE>-knob until the number of the desired memory appears.
4. Press <ENTER>.

APPLICATION

In this menu option you can change Oden AT's mode of operation for different types of tests.

The available settings are listed in the table below.

Application	
Menu	Description
""NORMAL USE""	Configures Oden AT for normal use.
""MICROMETER""	Oden AT will work as a microhmeter.
""TEST RECLOSER""	Sets Oden AT to test a direct-acting automatic recloser.
""PULSES""	Sets Oden AT to generate a pulse train.
""SECTIONALIZER""	Sets Oden AT to test a sectionalizer.

6 How to install Oden AT

6.1 Safety

DANGER
 When you are changing the connections make sure that current not can be generated accidentally. Disconnect the mains supply or switch the miniature breaker F2 to the 0-position.

WARNING
 The current output terminals and connecting points can be hot after generation of high current.

All current units used must also be connected to the control unit. Otherwise the current unit might be damaged.

Do not connect two or more ODEN AT systems in parallel or series. This can damage ODEN AT.

6.2 Loading Oden AT onto a carriage

The components of Oden AT (i.e. the control unit and the current units) can be mounted on a carriage for easy transportation. The carriage also serves as a platform and helps to raise the control unit to a comfortable working position.

WARNING
 To prevent tip-over, the current units must be loaded onto the carriage from bottom up.

The carriage is primarily intended for transportation but may also be used when testing. The carriage must then be secured to prevent tip over. It should withstand a horizontal force of 250 N (N = Newton, approx. 56 lbs of force) in any direction applied anywhere on the equipment.

If securing is not possible stack the units on a flat surface that can support the load of the units. Make sure that the stack will withstand a horizontal force of 250 N in any direction applied anywhere to the equipment.

The steel brackets mounted on the carriage are only intended for keeping the Oden AT units in place during transportation. They are not dimensioned to carry the weight of a current unit. A current unit should always rest either on the loading pallet or on top of another current unit.

Place the first current unit on the bottom loading pallet of the carriage. Make sure that the current unit



Fig 6.1 Different positions for the Oden AT carriage. Note, in working position the carriage must be secured to prevent tip over. Secure it to a suitable object e.g. a pole or a table.

is held in place by the steel brackets on the carriage. Place the next current unit on top of the first. Make sure that it too is held in place by the brackets. The control unit should be mounted last.

When the carriage is in the working position the control unit can be mounted on the uppermost pair of brackets for easy access to the controls. When the carriage is used for transportation or is placed in the resting position, the control unit should be placed on top of the uppermost current unit to ensure stability. See fig 6.1

6.3 Connecting the test object and the current units to each other

Important!

Do not use old current units (which have 16-pin connectors) together with any newer current units, i.e. type S, H or X (which have 24-pin connectors).

Incorrect connections will result in erroneous measured values and might cause damage to the current units.

When you connect Oden AT to the object being tested, you should check that the contacts on the connectors are clean and that the cable clamps are placed as close together as possible on the object being tested. You must also remember that different types of cables have different capacities for carrying high currents.

To minimize the voltage drop in the cables from Oden AT to the object under test you can:

- Use two or more cables in parallel.
- Use as short cables as possible.
- Use cables with heavier gauge (thicker) conductors.
- Twist cable pairs. When units are connected in parallel only cables running from the same current unit are to be twisted together.

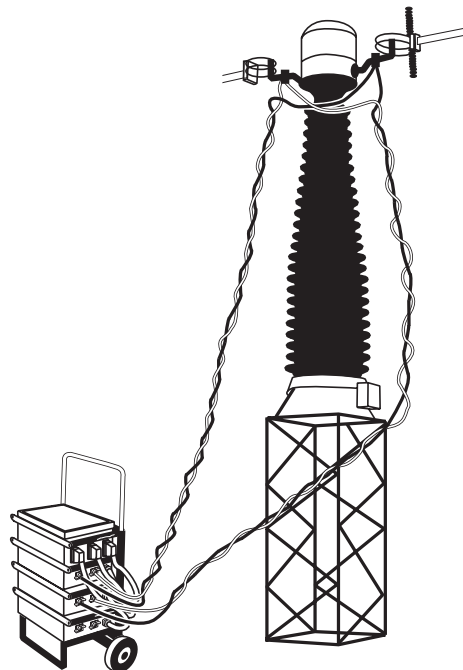

Fig 6.2 Example of how cables can be run

There are three types of current units; type S, type H and type X. If you want to use two or three cur-

rent units, you can connect them either in series or in parallel. The different connection variants are explained later in this chapter.

- Do not connect units that are of different types to each other. Only connect type S units to type S units, type H to type H etc.
- When using several current units of type X, the switch 0-30V/60V must be set in the same position on all currentunits.

6.4 Series connection (output HIGH I)

Use series connection when you want a high voltage at a high load impedance. For more information see chapter 11 "Specifications".

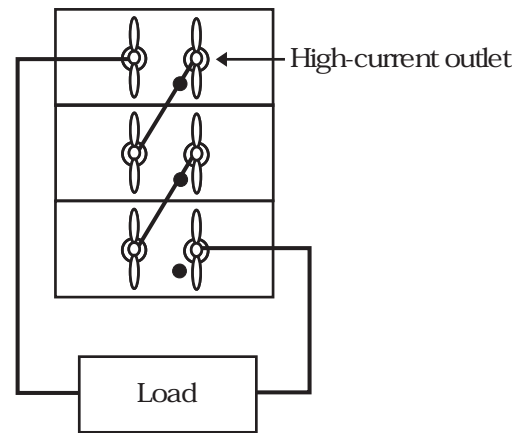

Fig 6.3 Units connected in series

6.5 Parallel connection (output HIGH I)

Use parallel connection when you need a low internal impedance in order to be able go generate high current. For more information, see chapter 11 "Specifications".

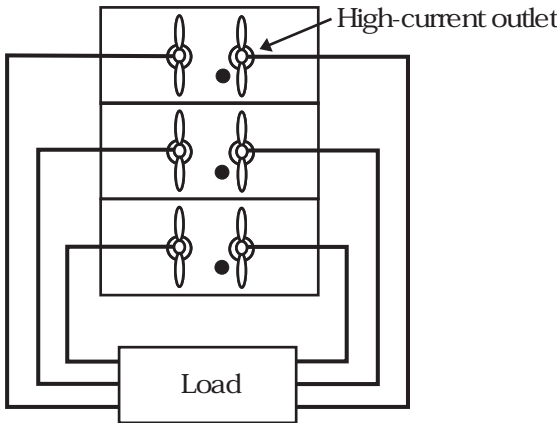

Fig 6.4 Units connected in parallel

6.6 Low-current output (output 0-30V/60V)



DANGER

The voltage at the output terminals can be dangerous. Especially when units are connected in series.

Never use a high-current output while simultaneously using a low-current output!



WARNING

Never switch between the 30 and 60 V settings when Oden AT is generating.

Important!

All type X current units that are connected together must have the same connection setting for the low-current output, i.e. 0-30 V or 0-60 V.

In addition to its regular high-current output, a type X current unit (which has an extra winding) has a low-current output that provides higher voltage (30 V or 60 V). You select the desired voltage by means of a switch on the current unit.

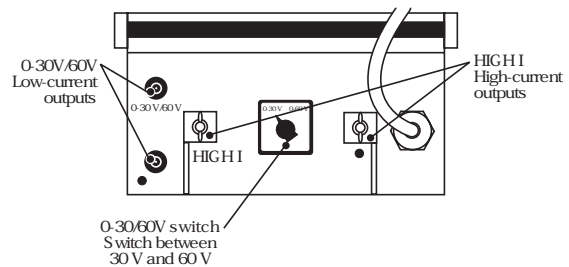

Fig 6.5 Current unit of type X

6.7 Connecting current units to the control unit

Important!

All current units used must be connected to the control unit.

Do not connect current units that are not used.

If two units are connected in series and three are connected to the control unit the showed current value will be false.

Current units are connected to the control unit via cables with a 24-pin onnector.

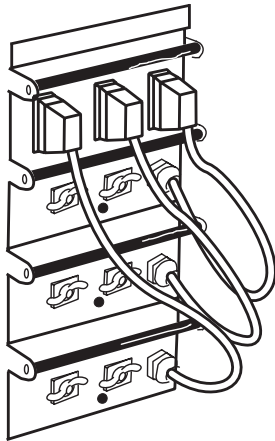

Fig 6.6 Current units connected to control unit

If you should want to connect an old current unit with a 16-pin connector to the control unit in an Oden AT, you must use a separately-ordered adapter.

6.8 Grounding Oden AT



DANGER

This equipment can be used only in electrical systems with single Ground. User must verify before connecting this unit to power, that High Voltage Ground and Low Voltage Protective Ground create a single protective ground with no measurable voltage potential existing between these ground systems. If a voltage potential is found between the ground systems please consult local safety regulations.



WARNING

Always use a grounded mains cable to connect the control unit to the mains, and in addition you must connect a separate ground cable. Connect the control unit to ground as described in fig. 6.7.

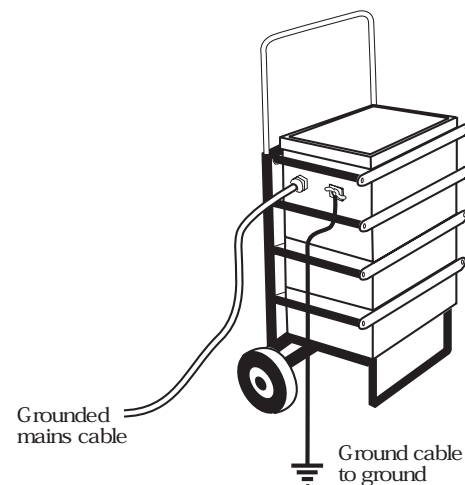

Fig 6.7 Oden AT connected to ground

6.9 Connecting Oden AT to the mains

Important!

Make sure that the mains voltage corresponds to that specified on the data plates on the control unit and the current units.

Make certain that mains outlet and its fuses and all cables/wiring have sufficient current-carrying capacity, i.e. suitable ratings.

Make sure that the fans in the current units are functioning when Oden AT is turned on.

Oden AT is a single phase unit. The mains input voltage should be connected between one phase and neutral or between two phases. Next to the mains inlet on the control unit is a data plate stating the mains input voltage and to which mains inlet contacts the voltage should be applied. Make sure that the input voltage is connected according to the instructions on the dataplate

The mains switch is located on the left side of the control unit.

Oden AT's power consumption will depend on the magnitude of the output generated and also on the mains voltage for which it is intended.

Power consumptions for different operating situations are set forth in chapter 11 "Specifications". Note that power consumption is higher for current units connecte in series.

6.10 Mains power supply

Mains voltage

ODEN AT is designed either for 240 V, 400 V or 480 V. The 480 V version is for 60 Hz only. ODEN AT by itself is a single-phase equipment but can of course be connected between two phases in a 3 phase system.

There is also a 400 V / 240 V version available. It is a 400 V version that also can be supplied from 240 V single-phase standard mains outlet. Please note that it can only be used on a 400 V system having a neutral. When supplied from a single-phase outlet, the mains supply fuse normally is rated 10 A or 16 A. This will limit the highest output current but it is still possible to get several kA for a short time with a slow 16 A fuse. No-load output voltage at 240 V supply is 60% of values specified in the Voltage – Current diagrams. Article no is BH-90120 and includes a mains adapter box.

Input Current

The input current is directly dependent on the output current and the ratio is stated for each configuration in the operators' guide. It can also be calculated for a 400 V or a 480 V 60 Hz version as:

$$\text{Output current} \times \text{Open circuit voltage}^1/400$$

and for a 240 V version as:

$$\text{Output current} \times \text{Open circuit voltage}^1/240$$

Calculated or specified values refer to worst case, i. e. when current setting is on its maximum. If settings only need to be at 50% to get the output current, input current is 50% of value above.

¹⁾ Open circuit voltage: Output voltage with current setting on maximum and no load connected

Mains cable and connectors

The inlet and connectors on the mains cable are of the European CEE standard type. However this connector is not usable in some countries. GE energy cannot deliver suitable connectors for all countries. Therefore you might need to replace the male connector on the mains cable. At ODEN AT's inlet is information about how mains supply should be connected.

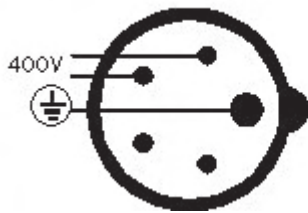

Connector on a control unit for 400 V

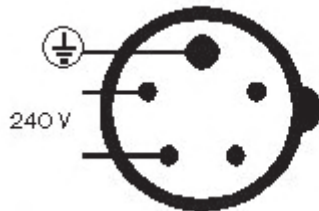

Connector on a control unit for 240 V

6.11 Current cables and conductors

Available cable sets

Please note:

- How important it is to twist the cables if possible. Values stated for twisted cables presuppose that each cable is twisted over the entire length. See section "How to arrange the cable sets".
- That it is possible to use several cable sets in parallel, for instance one set for each current unit. This will decrease impedance and increase continuous current capability. Divide impedance by number of sets in parallel. A separate end-bar, ordering no. BH 90-100 can be used to interconnect the cable set to get a single bolt connection to the test object.

Standard multi-cable sets

Cable sets consist of up to six pairs of 120 mm² cables in parallel. At each end there is an end-bar interconnecting the cables. The bar also enables single bolt connection to ODEN AT and the test object. See figure below.

Impedance of the cable set is very dependent on how cables are arranged. See section Hwt arrange the cable sets



Multi-cable 6 x 120 mm² with end-bar

Length 2 x 0.5 m (distance to test object 0.5 m)								
Number of cables	Total cross section area	Impedance cables twisted (mW)	Impedance cables not twisted (mW)	Impedance cables 1 m apart (mW)	Max. current in 20 sec. (A)	Max. cont. current (A)	Weight (total set) (kg)	Article number
1 pair	120 mm ² (1 x 120)							
2 pairs	240 mm ² (2 x 120)	0.21	< 0.53	-	3 200	700	4.6	GA-12205
3 pairs	360 mm ² (3 x 120)	0.18	< 0.46	-	4 800	1 050	6.0	GA-12305
4 pairs	480 mm ² (4 x 120)	0.16	< 0.40	-	6 400	1 400	7.3	GA-12405
6 pairs	720 mm ² (6 x 120)	0.14	< 0.35	-	9 600	2 100	10.0	GA-12605

Length 2 x 1.0 m (distance to test object 1.0 m)								
Number of cables	Total cross section area	Impedance cables twisted (mW)	Impedance cables not twisted (mW)	Impedance cables 1 m apart (mW)	Max. current in 20 sec. (A)	Max. cont. current (A)	Weight (total set) (kg)	Article number
1 pair	120 mm ² (1 x 120)							
2 pairs	240 mm ² (2 x 120)	0.32	< 0.80	-	3 200	700	7.3	GA-12210
3 pairs	360 mm ² (3 x 120)	0.25	< 0.63	-	4 800	1 050	10.0 k	GA-12310
4 pairs	480 mm ² (4 x 120)	0.21	< 0.53	-	6 400	1 400	12.7 k	GA-12410
6 pairs	720 mm ² (6 x 120)	0.18	< 0.45	-	9 600	2 100	18.1 k	GA-12610

Length 2 x 1.5 m (distance to test object 1.5 m)								
Number of cables	Total cross section area	Impedance cables twisted (mW)	Impedance cables not twisted (mW)	Impedance cables 1 m apart (mW)	Max. current in 20 sec. (A)	Max. cont. current (A)	Weight (total set) (kg)	Article number
1 pair	120 mm ² (1 x 120)							
2 pairs	240 mm ² (2 x 120)	0.42	< 1.10	< 1.70	3 200	700	10.0	GA-12215
3 pairs	360 mm ² (3 x 120)	0.32	< 0.80	< 1.30	4 800	1 050	14.1	GA-12315
4 pairs	480 mm ² (4 x 120)	0.27	< 0.70	< 1.10	6 400	1 400	18.1	GA-12415
6 pairs	720 mm ² (6 x 120)	0.21	< 0.53	< 0.84	9 600	2 100	26.2	GA-12615

Length 2 x 2.0 m (distance to test object 2.0 m)								
Number of cables	Total cross section area	Impedance cables twisted (mW)	Impedance cables not twisted (mW)	Impedance cables 1 m apart (mW)	Max. current in 20 sec. (A)	Max. cont. current (A)	Weight (total set) (kg)	Article number
1 pair	120 mm ² (1 x 120)							
2 pairs	240 mm ² (2 x 120)	0.53	< 1.30	< 2.10	3 200	700	12.7	GA-12220
3 pairs	360 mm ² (3 x 120)	0.39	< 1.00	< 1.60	4 800	1 050	18.1	GA-12320
4 pairs	480 mm ² (4 x 120)	0.32	< 0.80	< 1.30	6 400	1 400	23.5	GA-12420
6 pairs	720 mm ² (6 x 120)	0.25	< 0.63	< 1.00	9 600	2 100	34.3	GA-12620

Multi-Cable sets with customised length

GE Energy can supply the Multi-Cable Sets with other lengths than specified above.

“L” refers to length of the set (maximum distance to the test object)

Impedance can be calculated:

Number of cables	Total cross section area	Impedance, cables twisted ¹⁾ (mW)	Max. current in 20 sec.	Max. cont. current	Weight (total set)
1 pair	120 mm ² (1 x 120)	(L x 0.43) + 0.1	1 600 A	350 A	(L x 2.7) + 1.9 kg
2 pairs	240 mm ² (2 x 120)	(L x 0.22) + 0.1	3 200 A	700 A	(L x 5.4) + 1.9 kg
3 pairs	360 mm ² (3 x 120)	(L x 0.14) + 0.1	4 800 A	1 050 A	(L x 8.1) + 1.9 kg
4 pairs	480 mm ² (4 x 120)	(L x 0.11) + 0.1	6 400 A	1 400 A	(L x 10.8) + 1.9 kg
6 pairs	720 mm ² (6 x 120)	(L x 0.07) + 0.1	9 600 A	2 100 A	(L x 16.2) + 1.9 kg

1) Impedance can be up to 2.5 times higher if the cables are running close together but not twisted and up to 4 times higher if they are 1 meter apart.

Example, customised Multi-Cable sets, length 2 x 5.0 m

Number of cables	Cross section area	Impedance cables twisted (mW)	Impedance cables not twisted (mW)	Impedance cables 1 m apart (mW)	Max. current in 20 sec.	Max. continuous current	Weight (total set)
1 pair	120 mm ² (1 x 120)	2.2	< 5.5	< 8.8	1 600 A	350 A	15.4 kg
2 pairs	240 mm ² (2 x 120)	1.2	< 3.0	< 4.8	3 200 A	700 A	28.9 kg
3 pairs	360 mm ² (3 x 120)	0.8	< 2.0	< 3.2	4 800 A	1 050 A	42.4 kg
4 pairs	480 mm ² (4 x 120)	0.65	< 1.6	< 2.6	6 400 A	1 400 A	55.9 kg
6 pairs	720 mm ² (6 x 120)	0.45	< 1.1	< 1.8	9 600 A	2 100 A	82.9 kg

Standard 2 X 5 M (single pair) cable set with clamps)

Cross section area	Impedance cables twisted (mW)	Impedance cables not twisted (mW)	Impedance cables 1 m apart (mW)	Max. current in 20 sec.	Max. continuous current	Weight (total set)	Article number
120 mm ² (1 x 120)	2.2	< 5.5	< 8.8	1 600 A	350 A	15.2 kg	GA-12052

6.12 How to arrange the cable sets

Minimising impedance in cables

Just increasing cross-section area helps only to a certain extent. When resistance is low, the major part of the impedance is caused by the *reactance*. Minimising the magnetic flux will reduce the reactance:

- Best is if a cable from a current unit terminal can be twisted together with a cable from the other terminal *on the same current unit*. This guarantee opposite current with same value which will almost neutralise the magnetic flux.
- If cables not can be twisted, keep cables with same current direction away from each other as much as possible
- Avoid loops or “windows”.



Current unit with twisted 2 pairs Multi-Cable Set

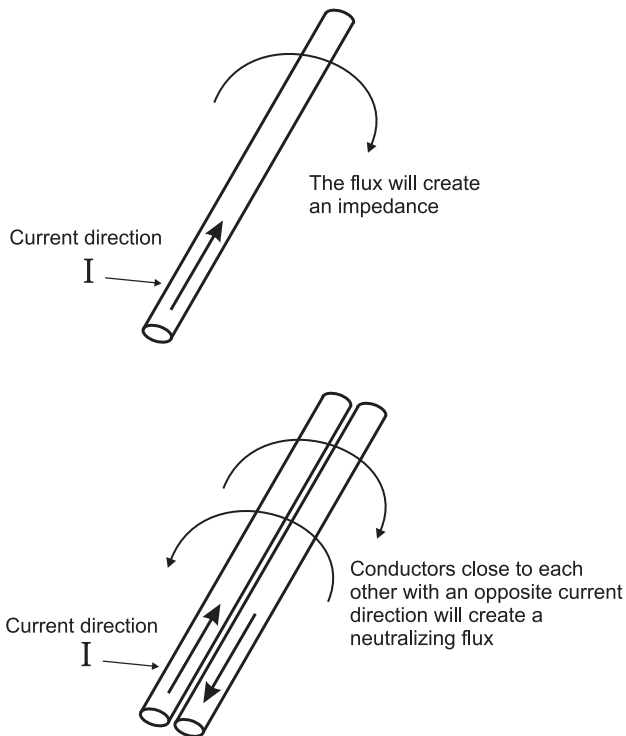

It is sometimes not possible or practical to twist the cables. However any action to keep cables with opposite current direction close together and to minimise loops helps. If the distances to the test object terminals are different it is better to use cables with different lengths in order to avoid loops.

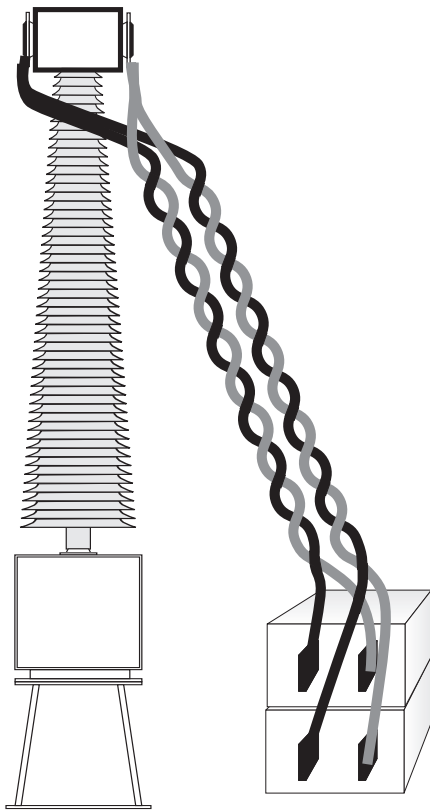

Case 1. Cables pair-twisted over their entire length.

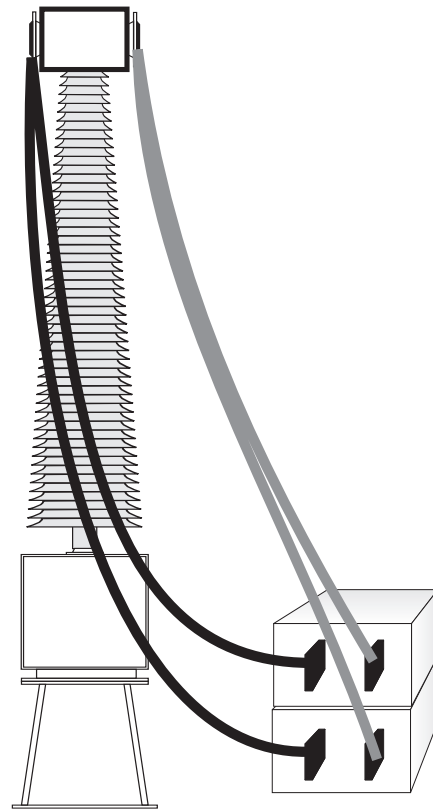

Case 3. Cables with opposite current direction 1 meter apart. Impedance is 2 to 4 times higher than in case 1.

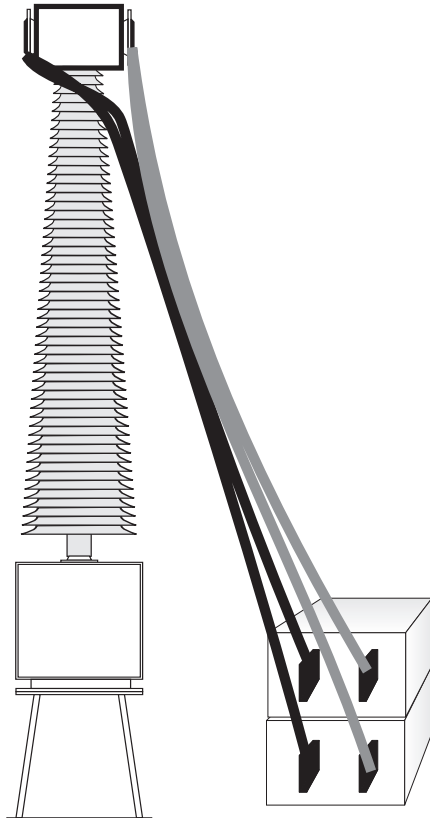

Case 2. Cables close together but not twisted. Impedance is 1.5 to 2.5 times higher than in case 1.

6.13 How To Arrange Bars

Copper-bars are in many cases a better solution than cables at high currents and short distances and at long load times. Bars must be specially designed for the actual test objects and in general this work must be the users responsibility. Here are some guidelines:

- Proper cross section area. Not less than 500 mm² - 1000 mm² (depends on the actual current). Take eventual heating into consideration.
- As close to the bar as possible (preferably maximum 1 mm) there should be another bar carrying the same amount of current in the opposite direction. This will neutralise the magnetic flux. Even if this arrangement slightly increases the length, it still is a gain because impedance due to magnetic flux is a bigger problem than the resistance.
- Do not use bars thicker than 10 mm and arrange the bars with their flat sides close together. The reason is that the magnetic flux (and the reactance) will be more effectively neutralised if the current is forced to flow close to the current with opposite direction.
- Loops (windows) that allow magnetic flux must be avoided).
- Joints must have low resistance

Example:

Two copper bars have the cross section 10 mm x 50 mm and they are mounted 5 mm from each other (the flat sides close together). Per meter of this arrangement the impedance is:

90 mΩ at 50 Hz (R = 73 mΩ and X = 54 mΩ)

98 mΩ at 60 Hz (R = 73 mΩ and X = 65 mΩ)

To get equal current from all current units.

When units are connected in parallel care must be taken that one unit does not supply the major part of the current. Otherwise its thermal protection can trip.

Method 1

There should be no parallel connections between the terminals of the current units. Make sure that the cable impedance between each current unit and test object is equal (same number of cables and same length).

Method 2

If number of cables used can not be evenly divided by the number of current units.

Make parallel connections between the terminals of the current units. Contact must be good, preferably use bars. Connect the cable set between the bars and the test object.

7 How to use Oden AT

This chapter describes the functions that you can perform using Oden AT. Complete test procedures are described in the next chapter, chapter 8 "Application examples".

7.1 How to generate current

1. Connect Oden AT to the object under test as described in chapter 6.
2. Turn on Oden AT using the mains switch on the side of the control unit.
3. Specify the desired settings in the OUTPUT block on the control panel.

Which output are you using?

- Specify HIGH I if you are using the high current output.
- Specify 0-30V/60V if you are using the output 0-30V/60V (only available on type X current unit).

Are current units connected in series or in parallel?

- Specify PARALLEL if you are using a single current unit.
- Specify PARALLEL if you are using several current units connected in parallel.
- Specify SERIES if you are using several current units connected in series.

4. Set the circuit breaker F2 in the I position.
5. Press <ON+TIME>. The value of the output current will appear on the display.
6. Adjust (set) the current using the coarse or fine adjustment controls.
7. If time test is included, press the <OFF> button to shut off the current.
8. Press <ON+TIME> to start a new generation with the correct current.

7.2 Rules of thumb when generating current

When you generate current there are rules which can be useful to follow:

- To reduce voltage drop, the current cables running to the object being tested should be as short as possible and have sufficient heavy-gauge (thick) cross-area. You can reduce the voltage drop further by twisting cables of different polarity together (see fig 6.2), thereby making it possible to inject higher currents.
- If the object being tested has a low impedance connect the current units in parallel. Connect them in series if the object has high impedance.
- To avoid unnecessary heating of objects being tested, current can be generated in brief intervals. It might be best to use manually-controlled (momentary) injection or time-limited injection. With Oden AT, it is also possible to make a coarse adjustment of the current using the I/30 function (which uses only 1/30th of the real test current).
- When operating time is measured, the value of the injected current or applied voltage must exceed the lowest operating limit by an ample margin (1.2 - 2 times is the rule of thumb here).

7.3 Setting the desired current

Low currents:

1. Connect the object being tested to a suitable Oden AT output.
2. Press <ON+TIME>.
3. Adjust the current using the coarse adjustment buttons or the fine adjustment knob. The value of the current will be presented on the display.

High currents:

High currents can generate a great deal of heat in both Oden AT and the object being tested. To avoid unnecessary heating, you can:

- Generate current only for brief intervals.
- Use the I/30 function .

Generating briefly

There are two easy ways to generate current for brief intervals: a) using the <MOM ON>-button or b) using the limited-time generation function. These are described in this chapter in section 7.13 "Measuring operating limits".

Using I/30 function

1. Connect Oden AT properly to the object being tested. See chapter 6 "How to install and connect Oden AT".
2. Activate the I/30 function.
3. Press <ON+TIME>. The current is displayed as "XXXX/30". XXXX represents the value the current will have when the I/30-function is released.
4. Adjust the current using the coarse adjustment buttons or the fine adjustment knob. The value of the current will be presented on the display.
5. Shut off the current using the <OFF> button.
6. Deactivate the I/30 function.
7. Activate the HOLD function by pressing <HOLD>.
8. Press the <MOM ON>-button briefly.
9. Read the current presented on the display.
10. Use the <FINE> knob for fine adjustment of the current.
11. Repeat, starting with step 8 above, until you have set the desired current.

Note: The I/30-function is less accurate on non linear test objects.

7.4 Setting times for limited-time generation (MAX TIME)

If you want to generate current throughout a limited time using the MAX TIME function, proceed as follows:

1. Press <AUTO OFF> in order to light up the MAX TIME lamp. The preset maximum generation time will appear on the display.
2. Set the desired generation time by turning the <CHANGE> knob. If you want the time expressed in another unit than the preset, you can enter a new unit under the TIMER menu heading in the <SYSTEM> menu option.



3. Start generation.

7.5 Continuous current generation

If you want to generate current for an unlimited time, i.e. until you shut generation off manually, proceed as follows:

1. Press <AUTO OFF> in order to turn off the STOP INPUT and MAX TIME lamps.
2. Start generation by pressing <ON+TIME>.
3. Set the desired current using the coarse and fine adjustment procedures.

7.6 Getting maximum current from Oden AT

Maximum output current is limited by the following:

- Impedance of the object being tested.
- Impedance of the current cables.
- Mains supply.
- Voltage drop in mains cables and other cables.
- Oden AT's internal impedance

To obtain maximum current from Oden AT proceed as follows:

- Connect two or three current units together.
- If the object being tested has high impedance, connect the current units in series.
- If the object being tested has low impedance, connect the current units in parallel.
- Use short, heavy-gauge (thick) cables and twisted cables, see fig 6.2.
- Make certain that the object being tested is connected properly (all connectors must be clean, connected at the right places etc.).

7.7 Improving the resolution of current settings

If you want to improve the accuracy of current settings, you can:

- Use a voltage that is as low as possible by (for example): a) not connecting the current units in series, b) using the high-current output even when low currents are to be generated, or b) connecting the low-current output for the lowest voltage (0-30 V) if you are using a single type X current unit.
- Increase the impedance in the circuit, for instance use longer, lighter-gauge (thinner) current cables.

7.8 Generating pulse trains

You can set Oden AT to generate a pulse-train (intermittent current generation at regular intervals, i.e. pulse-pause-pulse-pause etc.). This will continue until you shut off generation, until a preset maximum time (MAX TIME) is reached or until the condition at the STOP INPUT is met.

1. Basic settings:
OPERATE: OFF
2. Set the desired current. See section 7.3 "Setting the desired current".
3. Press the <APPLICATION> menu option.
4. Turn the <CHANGE> knob until "PULSES" appears on the display and press <ENTER>.
5. Set the pulse duration (TIME ON) by turning the <CHANGE> knob and press <ENTER>.

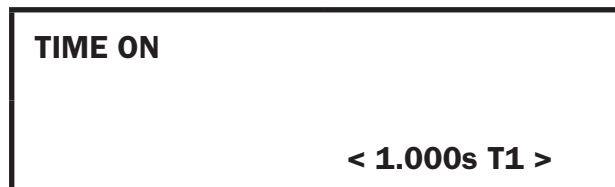

6. Set the desired between-pulse pause (TIME OFF) by turning the <CHANGE> knob and press <ENTER>.

Note: You can select the unit in which time is to be expressed under the TIMER menu heading in the <SYSTEM> menu option.

7. Press <ON+TIME> or <MOM ON> to start the test. The word "OPERATE" appears on the display indicating that Oden AT is generating.



Note: The counter on the display (":OP") is intended mainly for use when testing sectionalizers. Each time the current is interrupted the counter value increases by one. The counter can count up to 127 pulses.

8. Generation stops when you press <OFF> or release the <MOM ON>-button or when the AUTO OFF-conditions are met.

7.9 Holding (freezing) measured values

Press the <HOLD> button to activate the holding (freeze) function. The function freezes a measured value when a signal arrives at the STOP INPUT or when the current is interrupted. When the hold function is activated the lamp in the HOLD button glows steadily. As soon as the stop condition has been met, the lamp in the HOLD button starts to flash.

The frozen values disappears when you start a new current generation operation or press <RESET>.

7.10 Measuring phase angle and polarity

Oden AT can display the phase angle between the current from Oden AT and a) the current (I2) passing through Oden AT's second ammeter (A-METER 2) or b) the voltage (V) at the voltmeter input. Press the <ESC>-button until the sign for degrees ("°") appears in the upper-left corner of the display.

Measuring current:

Current direction is defined as illustrated in fig 7.1.

Example:

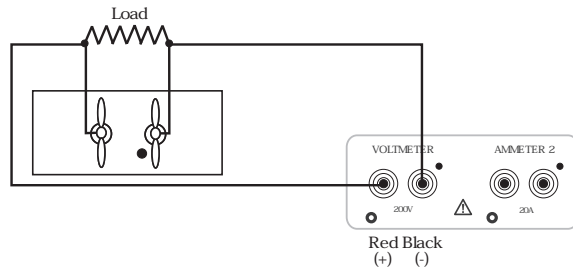

Fig 7.4

Phase displacement caused by an inductive load. Voltage lies 60° ahead of current. 60° appears on the display.

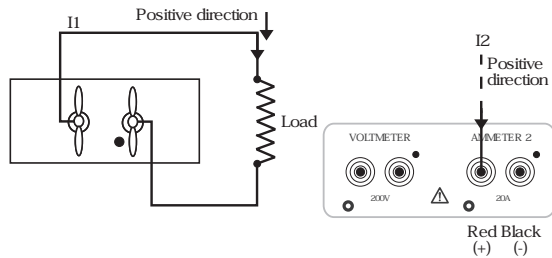

Fig 7.1

I1 is the reference current and the range is 0-360°.

The number of degrees that I2 is displaced **ahead** of I1 appears on the display.

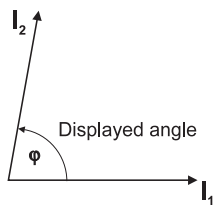

Fig 7.2

Measuring voltage:

Current direction is defined as illustrated in fig 7.3:

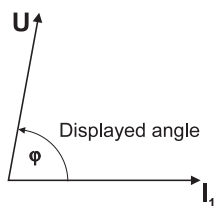
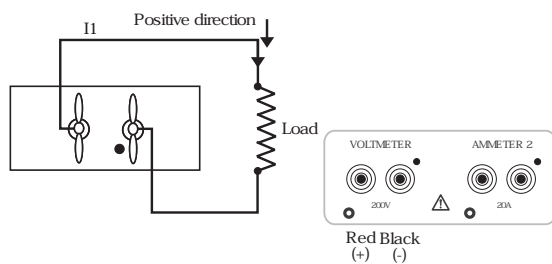

Fig 7.3

I1 is the reference and the range is 0-360°. The number of degrees that voltage (V) is displaced **ahead** of I1 appears on the display.

7.11 Measuring Z, P, R, X, S, Q and power factor ($\cos \varphi$)

When Oden AT's voltmeter is activated you can measure impedance (Z), active power (P), resistance (R), reactance (X), virtual power (S), reactive power (Q) and power factor ($\cos \varphi$). You can scroll through these quantities by pressing the <ESC>-key several times. Scrolling is possible even if the measurement is frozen.

300ms	
800A	0.558V

Standard: Time displayed on upper row.

Pressing the <ESC>-key once provides:

	1.434Ω Z
800A	0.558V

Continue scrolling to view the desired quantities.

	0.866$\cos \varphi$
800A	0.558V

7.12 Reading maximum current at an operation

The highest current value showed on the display at an operation is stored. Press <ESC> repeatedly until a current value and the text "max" appears. The maximum current value is updated every 1/3 sec.

7.13 Measuring operating limits

There are three ways to measure operating limits:

- Normal generation. Used when there is little risk for undesirable heating in the object under test.
- Manually-controlled momentary injection.
- Limited-time generation. Used when you do not want to expose the object under test to needless heating.

Method 1: Normal injection; gradually increase in current.

In this method current is sent out continuously. The current is gradually increased until the object being tested operates. When this happens a) the LATCHED lamp lights up, b) the current value is frozen on the display and c) the current to the object is interrupted.

When you are testing protective relay equipment you can, as a next step, reduce the current and freeze the displayed value to obtain information about the drop-out function.

1. Basic settings:

OPERATE: OFF
 CURRENT ADJUST: Lower than the tripping/operating limit.
 HOLD function: ON.
 AUTO OFF: STOP INPUT.

2. • For protective relay equipment:
 Set the stop condition to (for example):



- For breakers:
 Set the stop condition to **INT**.

3. Start generation by pressing <ON+TIME>.
4. Increase the current until operation occurs.
5. The value frozen when operation occurred is now presented on the display.

Note! If the impedance of the object under test changes during operation, you should use the maximum current value during the operation as pick-up value. Press <ESC>-button to get the maximum value, see section 3.1. MENU block.

The following apply only when testing protective relay equipment:

6. In order to measure the **drop-out** function, change the stop condition to (for example):



7. Start generation by pressing <ON+TIME> and turn up the current until the protective relay equipment operates (pick-up).
8. Turn down the current until drop-out occurs. The value frozen when drop-out occurred is now presented on the display.

For protective relay equipment you can simplify the procedure by testing both the pick-up and drop-out functions with a single current generation operation. This can be accomplished as follows:

1. Basic settings:

OPERATE: OFF
 CURRENT ADJUST: Lower than the tripping/operating limit
 HOLD function: ON
 AUTO OFF: Turn off the AUTO OFF function (neither the STOP INPUT nor the MAX TIME lamp will be lit)

2. Select the stop condition:



3. Start current generation.
4. Increase the current until the protective relay equipment operates (pick-up).
5. Read the pick-up function value from the display.
6. Press <RESET>.
7. Turn down the current until the protective relay equipment drops out. You can now on the display read the value that was frozen when drop-out occurred.

Method 2: Manually controlled momentary injection

Here, current is sent out as long as you hold down the <MOM ON> button. This method is useful when you do not want to expose the object being tested to unnecessary heat.

1. Basic settings:

OPERATE: OFF
 CURRENT ADJUST: Close to the operating limit
 HOLD function: ON
 AUTO OFF: STOP INPUT

2. • For protective relay equipment:
 Set the stop condition to (for example):



- For breakers:
 Set the stop condition to **INT**

3. Press <MOM ON> briefly. Note, however, that current must be sent out for a period longer than the operating time.
4. Read the current from the display.
5. Change the current setting somewhat.
6. Repeat, starting at step 3 above, until you find the lowest current that provides operation.

Method 3: Limited-time generation

Here, current is sent out for a limited period of time and interrupted when a present maximum time (MAX TIME) is reached. This method is useful when you do not want to expose the object being tested to unnecessary heat. Section 7.4 “Setting times for limited-time generation (MAX TIME)” in this chapter explains how to set MAX TIME.

1. Basic settings:

OPERATE: OFF
 CURRENT ADJUST: Close to the tripping/operating limit
 HOLD function : ON
 AUTO OFF: Specify MAX TIME (choose a generation time that is longer than the operating time) and also specify STOP INPUT

2. • For protective relay equipment:
Set the stop condition to (for example):



- For breakers:

Set the stop condition to **INT**

3. Start injection by pressing <ON+TIME>.
4. Read the current on the display after generation has stopped.
5. Change the current setting somewhat.
6. Repeat, starting at step 3 above, until you find the lowest current that provides operation.

7.14 Measuring tripping/operation times

Here, generation continues until the protective relay equipment operates or the breaker trips. To avoid unnecessary heating or operation of the object being tested, the I/30-function can be used (see section 7.3 “Setting the desired current” in this chapter) while the current is being adjusted.

1. Basic settings:

OPERATE: OFF
 CURRENT ADJUST: Lower than the operating limit.
 HOLD function ON.
 AUTO OFF: STOP INPUT.

2. Set the stop condition to (for example):



3. Start generation by pressing <ON+TIME>.
4. Set the current at which the operating time is to be measured. The current must exceed the operating limit by an ample margin.
5. Turn off the current by pressing the <OFF>-button.
6. Press <ON+TIME> again and wait until the stop condition is met.
7. Read the time and the current from the display.

7.15 Instantaneous trip unit measurement

You can test the instantaneous trip for breakers and for protective relay equipment as follows:

- When you test the **instantaneous pick-up** you can generate current by using the <MOM ON> button. This permits you to find the instantaneous pick-up without operating the overcurrent stage.
- You can also use limited-time generation (MAX TIME) to obtain the desired generation time.

Manually-controlled momentary injection is described below:

1. Basic settings:

OPERATE: OFF
CURRENT ADJUST: Close to the operating limit
HOLD function: ON

2. For protective relay equipment:

Set the stop condition to (for example):



- For breakers:

Set the stop condition to **INT**

3. Select a suitable current setting.
4. Press <MOM ON> briefly. The interval through-out which current is sent out must be shorter than the overcurrent stage's tripping/operating time.
5. Change the current setting somewhat and repeat, starting at step 4 above, until you find the lowest current that provides instantaneous pick-up.

When you test the **instantaneous trip time** make the following settings. Use the I/30 function (described in section 7.3 "Setting the desired current" in this chapter) while making current adjustments to avoid undesired operation of the object being tested.

1. Basic settings:

OPERATE: OFF
CURRENT ADJUST: Instantaneous operating limit
HOLD function: ON
AUTO OFF: STOP INPUT

- For protective relay equipment:

Set the stop condition to (for example):



- For breakers:

Set the stop condition to **INT**

3. Inject briefly using the <MOM ON>-button.

4. If necessary readjust the current and inject again. Repeat this until you have achieved the desired current value. Deactivate the I/30 function.
5. Inject until the test object operates and the operating time is presented on the display.

7.16 Selecting Oden AT configuration and current cables

Introduction

Different applications have various requirements on current and load time and the test objects have different impedance. The ODEN AT concept has three types of current units and they can be connected in series or in parallel. So there are good possibilities to find a configuration that meet your requirements.

Examples of different applications:

- Up to 5 - 7 kA through 5 m current cables. Applications: Test of outdoor apparatus.
- > 10 kA through a low-impedance test object placed close to ODEN AT. Applications: Test of Low Voltage Circuit Breakers and joints.
- More than 100 V to push currents up to 400 A. Applications: Primary injection through cables or lines.
- Continuous current generation. Up to 2.5 kA through 5-m current cables. Up to 3.8 kA if test object has low impedance and bars are used as current conductors.

Available systems

- Any system must have a control unit
- There can be 1, 2 or 3 current units in a system
- There are 3 different types of current units: S (Standard), X (Extra output) and H (High current)
- All current units in a system must be of same type
- A system can be designed for either 240 V or 400 V mains supply

Altogether there are 18 different ODEN AT systems. Furthermore, the current units can be connected in parallel or series. In total there are 46 different configurations available. Their specifications are present in the chapter "Specification".

The system designation indicates the number and type of current units.

Example:

ODEN AT / 2X

2 = Quantity of the current units

X = Version of current units

Test circuit impedance limits the current

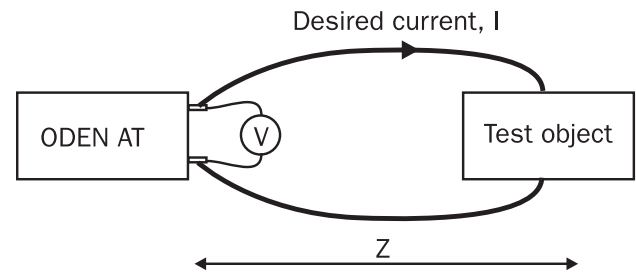

The test circuit impedance Z consists of current cable impedance and impedance of the test object. According to Ohms law $I \times Z$ volt is required to push current I through the impedance. If voltage at ODEN AT terminals is less, current will be lower than desired.

Note! Voltage is required to get current through the impedance and you need to know the impedance of the test circuit.

Please not only look at the maximum rated current of the ODEN AT configuration. You must also check that the available voltage at ODEN AT's output terminals (see chapter 11 Specifications) is sufficient to push current through the test circuit.

The current capability is dependent on the load time. You must also check in the load time - current diagram that the system can generate the desired current for the required load time.

7.17 How to succeed in selecting a suitable ODEN AT system

Please follow the procedure below. It implies that you first choose configuration and then suitable current cables. At the end of this chapter you will find two forms (Form 1 and Form 2) useful for the procedure. Form 2 is for cases where you must use a certain cable set (length, cross section or weight restrictions).

Required information

- Application
- Desired Current
- Desired load time
- Distance to the test object
- Is it possible to twist current cables
- Impedance and type of test object
- Mains voltage supply and its current capability

Distance to the test object

- Use as short cables as possible
Length (impedance) has a direct impact on maximum possible current. There is no reason to burn power in unnecessarily long cables.

Impedance of the test object

Knowledge saves you from surprises

- Test object impedance has most impact at higher currents and when current cables are short.
- Test object impedance is less important when cable set is 5 meters or longer and only consists of one or two cables each side. Then cable set impedance is the major part of the test circuit impedance.
- Test object impedance can be measured. Inject an AC current, measure voltage drop directly across the object. Divide voltage by the current to get the impedance ($m\Omega = V / kA$).
If possible, current magnitude should be the same as when testing the object. Some test objects saturate at high currents and measurement at low currents will give a too high impedance value.

Note! Do not use a DC - microhm meter for measuring. You will get a too low value since the reactive part is excluded.

- Test object impedance can be estimated from experience. Some examples:

- Low Voltage air breaker rated 4 kA:
0.09 - 0.2 m Ω
- Low Voltage circuit breaker rated 630 A:
0.3 - 1m Ω
- Outdoor breaker pole or disconnecter:
0.2 - 0.5 m Ω

In general test objects rated for higher currents have lower impedance

Regarding current transformers, the impedance in the secondary circuit has a direct impact on the impedance. Shunting secondary circuits not included in the test reduces but some users dislike to do that. For out-door current transformers current cable impedance is usually the problem, not impedance of the CT.

Procedure

- Available mains supply

Should a 240 V version or a 400 V version be used?

400 V version or 480 V 60 Hz version

- requires less input current
- has higher current capability at short duration load

Note! There is a 400 V version which also can operate at 240 V (reduced output voltage) provided that the mains system has a neutral

240 V version

- has in some cases higher continuous rating

See further chapter 3, section "Mains power supply".

- Load time - Current & Output Voltage - Current

- Check Time-Current and Voltage-Current diagrams in the chapter "Specifications". Select a configuration that fulfils Time-Current requirements and has reasonably high output voltage.
- If no configuration meets the requirements there is no reason to proceed. However please check your requirements once more. Do you really need the current magnitude and the length of the cables?

- Calculate maximum allowed test circuit impedance

Test circuit impedance = Output voltage / Current
($m\Omega = V / kA$)

- Calculate maximum allowed cable set impedance

Subtract test object impedance from test circuit impedance.

(Simplification. Both cable set and test object are inductive)

5. Select current cables / conductors

You know the length. Select from tables in chapter 3, "Current cables and conductors".

- Impedance may not exceed maximum allowed value. It should be as low as possible but cable set should not be unnecessarily clumsy or heavy.
- Impedance can be reduced by:
 - a) twisting cables since it reduces the reactance. Important!
 - b) using sets with more cables
 - c) using several cable sets in parallel. This is especially useful when current units are used in parallel.
- At continuous or long term load:

Check that the current per cable not will be too high (a 120 mm² cable can withstand 350 A continuously). If so, use a set with more cables in parallel.
- Weight. Overhead test object must be able to carry the weight of the cable set. Divide weight by 2 to get load at one side of the test object or check if the cables can be supported by other method.
- Solid bars can be a better solution than cables at high currents and short distances.
- If distances to test object terminals are different, using a set with different cable lengths can reduce impedance. This also makes twisting easier

5. Rules of thumb

- a) Distance max. 1 meter, current 5 - 15 kA
(For example Low Voltage Circuit Breaker testing)

Minimise cable impedance. Weight is a minor problem. Use cable set with many cables in parallel or bars.

- b) Distance 5 meters or more, current max 3 kA and time max. 10 seconds:
(For instance at outdoors Current Transformer testing)

Since current is moderate and load time is short, it is possible to use a cable set that is not too clumsy. One or two cables in parallel each side is sufficient in many cases, especially if it is possible to twist the cables.

- c) Distance 5 meters or more and current > 3 kA:
(for instance outdoor Current Transformer testing)

Low impedance must be given highest priority in order to get the desired current. This means many cables in parallel. Unfortunately it is unavoidable

that the cable set will become rather heavy.

- d) Continuous or long injection time.
(for instance at heat run)

First you must check that cable set has sufficient number of cables that current through a single cable does not become too high.

6 Check input current

Again, to avoid surprises. ODEN AT is like a transformer, high output power requires high input current. Your mains supply must be able to supply the current.

See also Chapter 6, section 6.10 "Mains power supply" and Chapter 11, "Specifications" for information how to calculate.

Current calculation example

- Q: Output voltage is lower than test circuit impedance x current? What is the highest possible current I can get?
- A: Draw a line in the voltage versus current diagram representing the impedance. The highest possible current is where impedance line crosses the voltage graph. See diagram below.

Example: An ODEN AT/3H with units in series is used and test circuit impedance is 1.2 mΩ. The line should start at 0 kA, 0V. Multiply 1.2 mΩ by for instance 10 kA to get another point (10 kA, 12V) and draw the line between the points. Highest possible current for an ODEN AT/3H with units in series (graph 3Hs) is 5.6 kA.

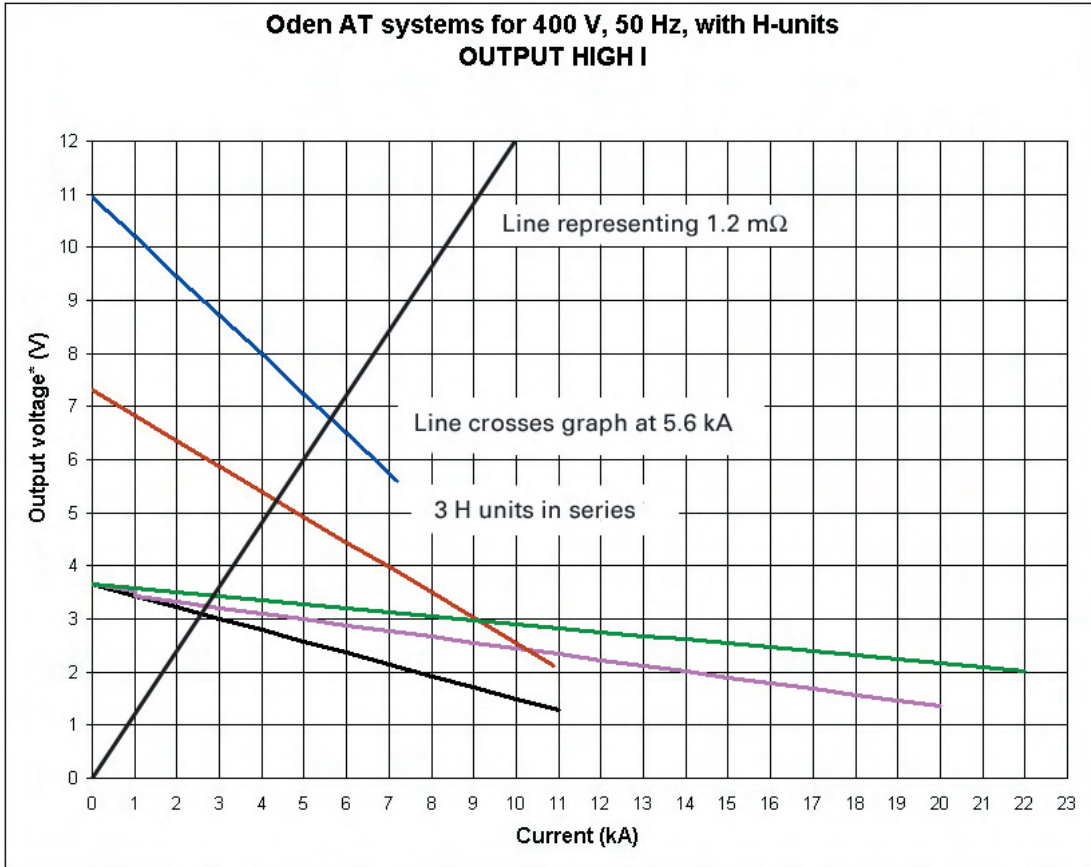

7.18 Examples

Example 1, Current Transformer

Conditions:

Current 3 kA

Cables can be twisted

Injection time 10 seconds

CT impedance 0.4 mΩ

Current cable length 5 meter

Mains voltage 400 V

2. Selected output configuration
ODEN AT 1/S is a possible choice. It can supply 3 kA for more than 10 seconds and has 4.0 V output voltage.
3. Maximum allowed test circuit impedance
 $3.9 \text{ V} / 3 \text{ kA} = 1.3 \text{ m}\Omega$
4. Maximum allowed cable set impedance
 $1.3 \text{ m}\Omega - 0.4 \text{ m}\Omega = 0.9 \text{ m}\Omega$
5. Select current cables
A cable set for 5 meter with 3 x 120 mm² cables has the impedance 0.8 mΩ if the cables are twisted. Weight at each side of the test object is 3 x 21.2 kg.
6. Input current
46 A



Tip If you consider 3 cables each side being clumsy, an ODEN AT 2/S with units in parallel can be chosen. Output voltage at 3 kA is 5 V and maximum test cable impedance is 1.6 mΩ . Two cable sets is enough since their impedance is 1.1 mΩ.

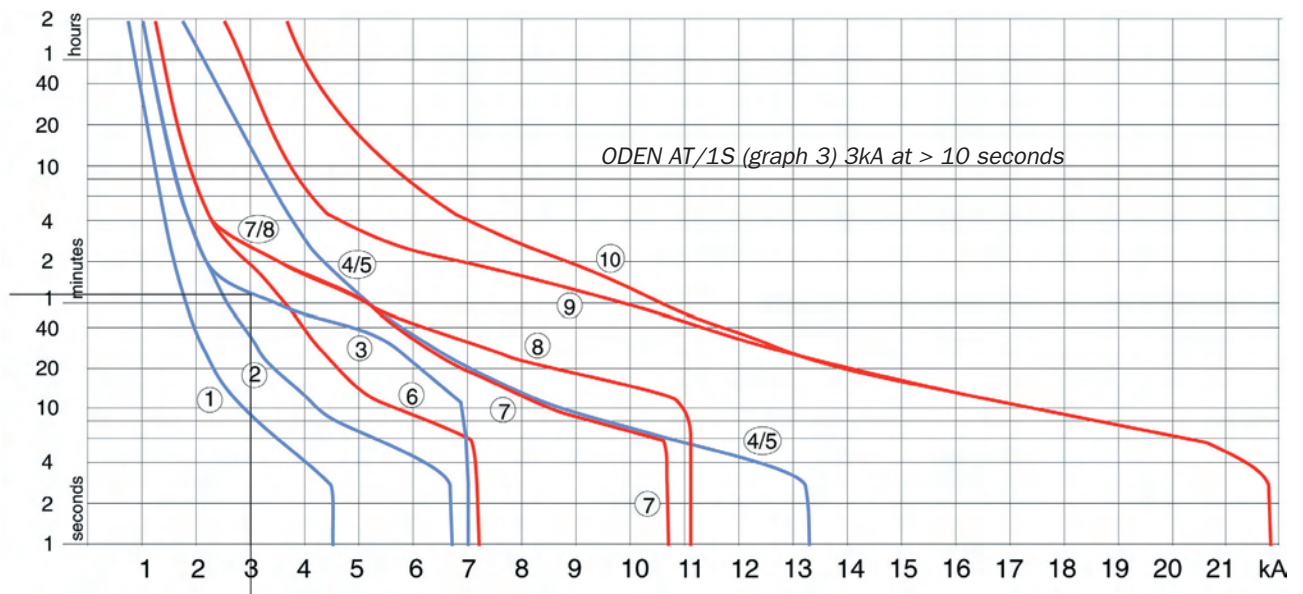

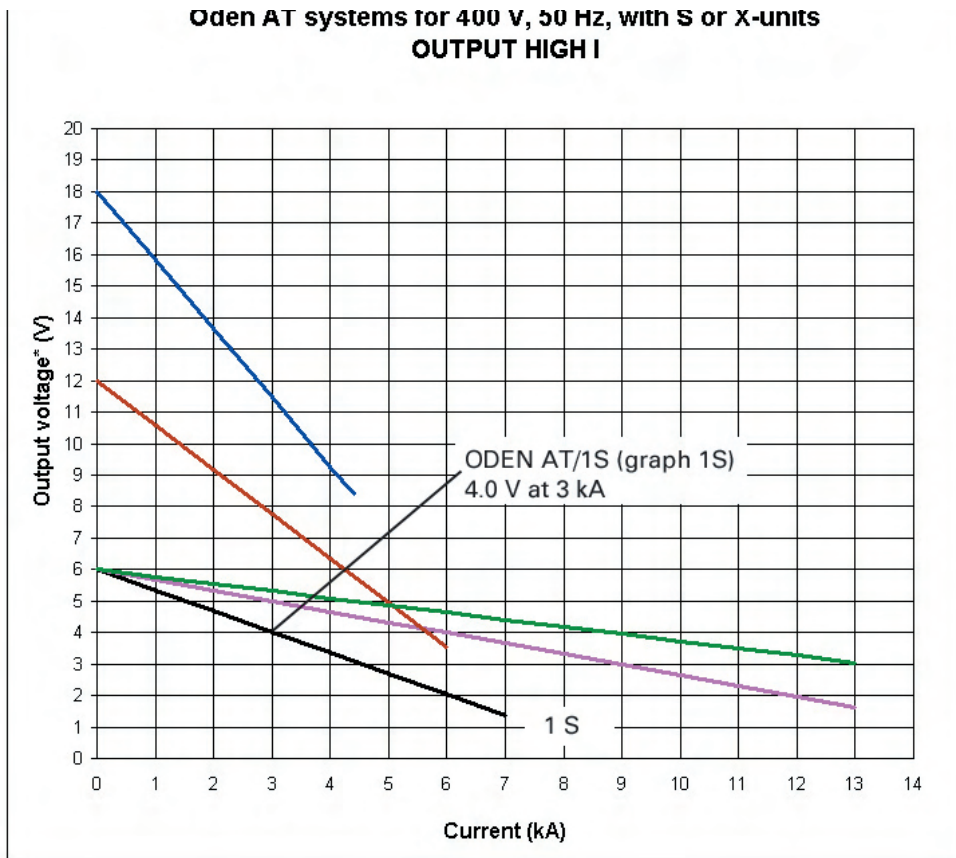

Example 2, Low Voltage Circuit Breaker

Conditions:

- Current 7 kA
- Cables can not be twisted Injection time 5 seconds
- Breaker impedance 0.15 mΩ
- Current cable length 0.5 meter
- Mains voltage 240 V.

2. Selected output configuration
ODEN AT 2/S with units in parallel can supply 7 kA for more than 5 seconds and has 3.6 V output voltage.
3. Maximum allowed test circuit impedance
 $3.6 \text{ V} / 7 \text{ kA} = 0.51 \text{ m}\Omega$
4. Maximum allowed cable set impedance
 $0.51 \text{ m}\Omega - 0.15 \text{ m}\Omega = 0.36 \text{ m}\Omega$
5. Select current cables
Set GA -12205 is 0.5 meter long and has impedance approx. 0.5 mΩ with untwisted cables. 2 of these sets (one for each current unit) gives impedance 0.25 mΩ. However, even better is to take two sets of GA – 12305. It will give better margins and less heating in the cables. Short cables are inexpensive and not heavy.
6. Input current
175 A

Example 3, Low Voltage Circuit Breaker

Conditions:

- Current 15 kA
- Cables can not be twisted
- Injection time 5 seconds
- Breaker impedance 0.1 mΩ
- Distance 0.5 meter
- Mains voltage 400 V

2. Selected output configuration
ODEN AT 3/H with units in parallel can supply 15 kA for more than 5 seconds and has 2.7 V output voltage.
3. Maximum allowed test circuit impedance
 $2.5 \text{ V} / 15 \text{ kA} = 0.17 \text{ m}\Omega$
4. Maximum allowed cable set impedance
 $0.17 \text{ m}\Omega - 0.1 \text{ m}\Omega = 0.07 \text{ m}\Omega$
5. Select current cables
 $0.07 \text{ m}\Omega$ is hardly possible with standard cable sets. Copper bars where the conductors with opposite current directions are close together should be used.
6. Input current
136 A

Form 1

Selection of configuration & cables

See explanations in chapter 7, "Selecting ODEN AT system and current cables"

Required information:

- Desired Current _____ A
- Desired load time _____
- Distance to the test object (Please check how short cables you can use) _____ m
- Can current cables be twisted? _____
- Test object type / impedance (not always necessary) _____ / _____ mΩ
- Available mains voltage and its current capability _____ V _____ A

1. Should a 240 V or a 400 V version be used?

- 240 V version: Sometimes higher continuous rating 240 V
- 400 V version: Higher short time current, lower input current 400 V

2. Select ODEN AT configuration

Check Time-Current and Voltage-Current diagrams in chapter "Specifications"
 Select a configuration that fulfils Time - Current requirements and has reasonable high output voltage.

Configuration _____

Series

Parallel

Output voltage _____ V

3. Calculate maximum allowed test circuit impedance

Test circuit impedance = Output voltage / Current (mΩ= V / kA) _____ mΩ

4. Calculate maximum allowed cable set impedance

Subtract test object impedance from test circuit impedance _____ mΩ

5. Select current cables / conductors

See chapter "Current cables and conductors"

Cable set _____ mΩ

Number of sets _____

Impedance of all sets _____ mΩ

6. Check input current

See chapter 3 "Mains power supply" or chapter 11 "Specifications"

Input current _____ A

Form 2

Selection of configuration when using a certain cable set

Use this form when you must use a certain cable set. See explanations in chapter 7, "Selecting ODEN AT system and current cables"

Required information:

- Application _____
- Desired Current _____ A
- Desired load time _____
- Distance to the test object _____ m
(Please check how short cables you can use)
- Can current cables be twisted? _____
- Test object type / impedance (not always necessary) _____ / _____ mΩ
- Available mains voltage and its current capability _____ V _____ A

1. Select current cables / conductors

See chapter 3, "Current cables and conductors"

Cable set _____ mΩ

2. Impedance of the test object

Most important at high currents and if current cables are short

_____ mΩ

3. Calculate test circuit impedance

Test circuit impedance = cable set impedance + test object impedance.

_____ mΩ

4) Calculate required output voltage

Required voltage = Test circuit impedance x Current (V = mΩ x kA)

_____ V

5) Select ODEN AT configuration and system voltage

Now you know required output voltage, load time and desired current.

Select a configuration that fulfils both Voltage-Current & Time-Current requirements.

See diagrams in chapter 11 "Specifications".

400 V version: Higher short time current, lower input current

240 V

240 V version: In some cases higher continuous rating

400 V

Configuration _____

Series

Parallel

6. Check input current

See chapter 3, "Mains power supply" or chapter 11, "Specifications".

8 Application examples

This chapter explains step-by-step how some specific objects are tested. The following are discussed:

- Testing a low-voltage circuit breaker
- Testing the turns ratio of a current transformer
- Testing the polarity of a current transformer
- Measuring the resistances of breakers and electrical connections (microhmmeter testing)
- Testing a direct acting recloser
- Testing a sectionalizer
- Testing a ground grid

8.1 Testing a low-voltage breaker

The following sections explain how to test a low-voltage breaker. Start by measuring the overcurrent stage's tripping limit and the tripping time. Then measure the tripping limit and tripping time for the instantaneous unit.

Measuring the tripping limit (normal generation):

Current is generated continuously and gradually increased until the breaker trips. When the breaker trips the current shown on the display is frozen and the current is interrupted. When current first is generated for a load (while the current is being set), Oden AT adapts itself so that all subsequent generation operations start at the current's zero-cross-over points. This ensures minimized transient DC offset when the injection is initiated.

1. Basic settings:

OPERATE:	OFF
CURRENT ADJUST:	Lower than the tripping limit
HOLD function:	ON
AUTO OFF:	STOP INPUT

2. Set the stop condition to INT.
3. Start generation by pressing <ON+TIME>.
4. Increase the current until tripping occurs (the LATCHED lamp lights up).
5. The current value frozen when tripping occurred can now be read from the display.

Note: You can read out the highest current value during an operation by pressing <ESC> repeatedly until "max" appears after a current value. This value should be used for test objects whose impedance changes during the operation.

Measuring the tripping time:

1. Set the current to an ample margin above the tripping limit. The procedure is described in section 7.3. Use the I/30 function (step 2 to 6 in section 7.3) if you want to set the current without operating the breaker.

Note: Disable the INT-function when you are using I/30.

2. Settings:

HOLD: ON
 AUTO OFF: STOP INPUT
 STOP INPUT: INT

3. Start generation by pressing <ON+TIME> or <MOM ON>.
4. Read the time and the current presented on the display.

Instantaneous trip unit measurement:

When you test the instantaneous pick-up you can provide a manually-controlled momentary current injection by pressing the <MOM ON> button. This permits you to find the instantaneous trip unit's lowest operating current without tripping the overcurrent stage.

1. Basic settings:

OPERATE: OFF
 CURRENT ADJUST: Close to the tripping limit
 HOLD function: ON

2. Set the stop condition to INT.
3. Select a suitable current setting.
4. Press <MOM ON> briefly. The time throughout which current is generated must be shorter than the overcurrent stage's tripping time. You can also use limited-time current generation (MAX TIME). See section 7.13 "Measuring operating limits".
5. Change the current setting somewhat and repeat from step 3 above until you find the lowest current that provides tripping of the instantaneous trip unit.

In order to measure the **instantaneous trip time** proceed as follows:

1. Increase the current to an ample margin above the tripping level.
2. Start an injection and read the time on the display.

8.2 Testing the ratio of a current transformer

This test determines whether or not a current transformer has the correct ratio. During the test, current is injected into the primary side of the current transformer, and the current in each secondary winding is measured using Oden AT's second ammeter (A-METER 2).

**WARNING**

Make certain that you observe all applicable safety regulations and precautions associated with dielectric strength on the secondary side. The secondary side of the transformer must be closed during the injection!

1. Basic setting:

OPERATE: OFF
 AMMETER1, UNIT: AMPERE

2. Connect the Oden AT output to the primary terminals on the current transformer.
3. Connect Oden AT's second ammeter (A-METER 2) input to the current transformer winding that is to be tested. Make certain that this winding is not connected to any other circuit.
4. Activate A-METER 2 in the <V/A METER> menu option under the "A-METER 2" menu heading.
5. Select "A-METER 2 NOM I" and set the nominal secondary current for the current transformer. You might, for example, set it to 5 A.
6. Select "A-METER 2 UNIT", and then select "CT ratio".
7. Press <ON+TIME>.
8. Set the desired primary current, whereupon both the primary current and the actual ratio will appear on the display.

Example:

1000 A injected into a transformer with a ratio of 5000/5.

5.107s	
1.00kA	5000/5 A

Note: Another method to measure the ratio between primary and secondary current is to set the unit for ammeter 1 to "I1/I2". Do not however try to combine the two methods!

8.3 Measuring the polarity of a current transformer

You can conduct a polarity test to determine whether or not the current direction in a current transformer is correct.

In this test it is to be verified that the terminal S1 (X1) on the secondary side is positive relative to terminal S2 (X2) when terminal P1 (H1) on the primary side is positive relative to terminal P2 (H2).

1. Basic setting:

OPERATE: OFF

2. Connect the one of the output terminals on Oden AT's which is marked with a dot (·) to P2 (H2) on the primary side of the CT.
3. Connect the other output terminal to P1 (H1).
4. Connect the one of A-METER 2:s terminals which is marked with a dot (·) to S2 (X2) on the secondary side of the CT.
5. Connect the other terminal of A-METER 2 to S1 (X1).
6. Activate Oden AT's second ammeter (A-METER 2) under the "A-METER 2" menu heading in the <V/A METER> menu option.
7. Press the <ESC>-button (normally twice) until the sign for degrees ("°") appears in the upper-left corner of the display.
8. Press <ON+TIME>.
9. Turn the current up until the a stable phase-angle appears on the display.
10. If the phase angle is close to 0° or 359° the polarity is correct. If the phase angle is 180°, the polarity is incorrect.
11. Press <OFF>.
12. Move the cables used for A-METER 2 to the other secondary windings and check them in the same way.

A sample hookup is shown in fig 8.1.

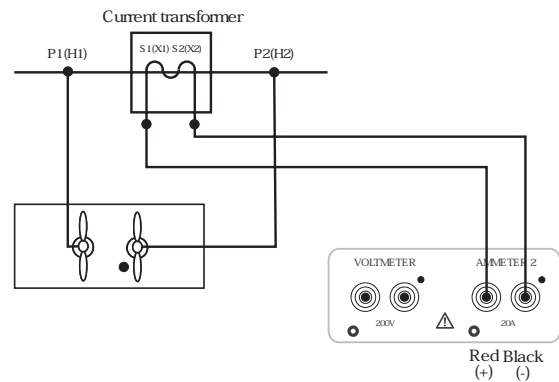

Fig 8.1





DANGER

Never ever make this hookup while current is being generated. If you do, you may be exposed to dangerously high voltages.

8.4 Measuring the resistances of breakers and electrical connections (microhmmeter testing)

You can measure the resistance of a breaker or an electrical connection by changing Oden AT's settings for microhmmeter testing.

WARNING
 You must make certain that all general safety precautions are taken. See chapter 1 "Safety precautions". You must also make certain that all local regulations which govern work with high-voltage equipment are complied with.

WARNING
 Before you connect Oden AT to a breaker, you must make certain that the breaker is closed and grounded on one side.

WARNING
 Do not measure on outdoor High Voltage Circuit Breakers due to risk for capacitively coupled currents. It could cause danger and/or damage.

WARNING
 If generated current must pass through the current transformer, the protective relay system must be blocked so that it cannot trip unintentionally.

If you are measuring the resistance of an object that has high core losses, the measured resistance will be in error. Highly inductive objects can also lead to erroneous readings.

The accuracy is best when the current and voltage measurement operates at more than 50% of the measurement range.

1. Connect the Oden AT current cables and sensing cables between the Oden AT voltmeter and the breaker. The cables in each cable set should run as close to each other as possible, i.e. there should be as few openings as possible where magnetic disturbances can get in and cause trouble.

2. Turn on Oden AT.

3. Basic setting:

OPERATE: OFF

4. Press the <APPLICATION> menu option.

5. Turn the <CHANGE> knob until "MICROHM-METER" appears on the display. Then press <ENTER>.

Oden AT will now automatically configure itself for microhmmeter testing as follows:

- The voltmeter is set to the lowest range.
 - The ammeter range is set to "AUTO".
6. Activate HOLD .
 7. If you want limited-time generation, activate MAX TIME and set the desired maximum generation time.
 8. Press <ON+TIME> and set the desired current .
 9. Current and $\mu\Omega$ values are displayed. Example:

Time	60.31s	$\mu\Omega$ M	Resistance in micro-ohms
Current	3.15kA	50$\mu\Omega$	

10. To return Oden AT to normal use, press the <APPLICATION>-button and then turn the <CHANGE> knob until "NORMAL USE" appears on the display. Press <ENTER> and Oden AT will be reset for normal use.

8.5 Testing a direct acting automatic recloser

Setting the current and testing the pick-up level is done in the same way as when testing low voltage circuit breakers, see section 8.1. Press <ESC> to obtain the maximum current during a test for reclosers that change their impedance.

At time tests Oden AT will generate current until <OFF> is pressed or until a preset maximum generation time is reached. After the cycle is completed the following measurements are stored and displayed:

- Number of operations (number of times the current is interrupted).
- The total accumulated time taken by the reclosing cycle (i.e. from the recloser's first trip to its last trip).
- The trip and reclosing times.
- The current at the first four trip operations.

The showed value is the average of the current at the beginning and the end of the operation.

Time test

1. Set the current, <APPLICATION> should be set to "NORMAL", see 8.1.
2. Press the <APPLICATION> menu option.
3. Turn the <CHANGE> knob until "TEST RECLOSER" appears in the display window and then press <ENTER>. Oden AT will now work as a recloser test equipment.

Note: Range for A-METER1 will automatically be changed to "LOW".

The HOLD feature is not active in TEST RECLOSER.

4. If you prefer limited-time measurement, activate MAX TIME and set the desired maximum generation time.
5. Press <ON+TIME> or <MOM ON> to start the test.

Oden AT now generates current continuously while the direct acting automatic recloser trips and closes alternately. For each time the current is interrupted, the number of operations ("OP" on the display) is increased by one on the display. Oden AT stores the trip (opening) times and reclosing times and the currents that prevailed when each trip and reclosing took place.

6. Generation stops when you press <OFF> or when the preset limited-time generation period (MAX TIME) is reached.

Total time to OFF	10.00s	RECL.	
Actual current	0A	3:0P	Number of operations

7. Display shows:
8. If you press <ENTER> the test results will be dumped via the serial-port, see appendix 1.
9. Press <ESC> to get more information on the display:

Total recl. time ¹⁾	9.015sTot	3:0P	
First trip pulse	985ms T1	39A	Current at T1

- 1) Displayed provided generation continued until lock-out
10. More information on the display can be seen by turning the <CHANGE>-knob.
11. Press <ON+TIME> to start a new test.
12. To return Oden AT to normal use, press the <APPLICATION>-button and then turn the <CHANGE>-knob until "NORMAL USE" appears on the display. Press <ENTER>.

8.6 Testing a sectionalizer

You can test a sectionalizer by making appropriate changes in Oden AT's settings. Here Oden AT sends out a preset sequence of current pulses corresponding to those that would be obtained from a direct-acting automatic recloser. After the cycle is completed, the following are stored and displayed:

- The number of current pulses until lockout (number of times the current is interrupted).
- The total accumulated time (i.e. from the recloser's first trip until its last trip).
- The trip times and the reclosing times.
- The current at the first four trip occasions.

Prior to the test 4 different puls-duration times (T1 - T4) and the reclosing time (R1 - R4) can be set.

Note: After pulse T4 and R4 a pulse T5 and a pulse R5 will be generated. T5 and R5 are identical to T1 and R1. Use the "MAX TIME" function to limit no. of pulses.

1. Set the desired current, see section 7.3 "Setting the desired current" for details.
2. Press the <APPLICATION> menu option.
3. Turn the <CHANGE> knob until "SECTIONALIZER" appears in the display window, and then press <ENTER>.
4. Set the time for T1 with the <CHANGE>-knob and press <ENTER>.
5. Set the times for R1, T2, R2 etc. in the same way and press <APPLICATION> .
6. If you want to use limited-time generation, activate MAX TIME and set the desired maximum generation time.
7. Press <ON+TIME> or <MOM ON> to start the test.
8. Generation stops when you press <OFF>, release the <MOM ON>-button or when the preset MAX TIME has been reached. The display shows:

Total time to OFF	10.00s	SECT.	
Actual current	0A	2:0P	Pulses until lockout

9. If you press <ENTER> the results will be dumped via the serial-port, see appendix 1.
10. Press <ESC> to get more information.

Total acc. time	9.786Tot	2: 0P	
Duration of pulse T1	214ms T1	38A	Current at T1

11. Scroll with the knob to get the times for R1, T2, R2 etc.
12. Press <ON+TIME> to start a new test .
13. To return Oden AT to normal use, press the <APPLICATION>-button and then turn the <CHANGE>-knob until "NORMAL USE" appears on the display. Press <ENTER> .

8.7 Testing a ground grid

The best method of testing the integrity of a ground grid is the High Current Method. An Oden AT equipped with a current unit of type X is very suitable for this kind of tests. Here is a brief description of how such tests is conducted with Oden AT.

A current of 300 A is to be injected between one reference ground electrode (usually the grounding point for a transformer) and the ground to be tested.

One criterium that must be met before a ground network can be approved is that at least 50% of the total current injected between points passes through the ground network. Moreover the voltage drop must not exceed 0.1V/meter.

Connect the output you intend to use for measurement (the 30 V output on a type X current unit for example) to the injection points. Then, in addition, connect the voltmeter input to the injection points.

1. Basic settings:

OPERATE: OFF
Voltmeter: Activate it in the <V/A METER> menu option
HOLD function: ON

2. Set Oden AT to generate 300 A, and allow the current to flow for about three minutes.
3. Then measure the portion of the current that flows through the ground network and the portion that proceeds via other routes using a clamp-on ammeter.
4. Read the voltmeter. The voltage drop must not exceed 0.1 V/meter.

9 Troubleshooting

9.1 General

Problem: No current is sent out from Oden AT

- Check miniature circuit breaker F2.
- Overheating may have triggered the thermal protection. The thermal protection resets itself automatically after Oden AT cools down.
- Check the connections to the object being tested. If a breaker is being tested, check to see that it is closed.
- Check the connection between control unit and current unit.
- For series connection, check that a series connection cable is being used and is connected properly.

Problem: Not possible to switch on Oden AT. The display is dark.

- Check the fuse F1 (located on the left side of the control unit).
- Check that the mains cable is plugged in properly and that mains voltage is present.

Problem: Generation stops immediately or after half a cycle.

Possible causes:

- Stop condition is set to INT and F2 is off.
Remedy: Close F2.
- Stop condition is set to INT and the output circuit is open.
Remedy: Change stop condition or close output circuit.
- Stop condition is set to INT and the output current is just a few percentage of the measurement range of ammeter 1, see 11.8.
Remedies: Increase the current, decrease INT-level or use range or output with lower current rating.

Note Connecting current units in series will decrease the measurement ranges.

Problem: Generation does not stop when the breaker opens.

- Zero offset need to be calibrated, see section 10.2 "Calibration of offset".

Problem: Unexpected value on Ammeter 1.

Possible cause: Improper settings in the OUTPUT block on the control panel.

Remedies:

- Select HIGH I if the high-current output is used.
- Select 0-30/60 V if the low-current output on a type X current unit is used.
- Select PARALLEL if the current units are connected in parallel or if you only have one current unit connected.
- Select SERIES if the current units are connected in series.

Possible cause: "SERIES" is selected in the OUTPUT block and unused current units are connected to the control unit.

Remedy: Disconnect unused current units.

Possible cause: Oden AT is set for DC-Measurement while AC is generated or vice versa. (Fault will be approx. 10%).

Remedy: Select proper setting for DC-Measurement (submenu system).

Possible cause: The test object has higher impedance than expected.

Remedies: Increase the voltage applied from Oden AT by connected the current units in series or use the low-current output if you have a type X current unit.

Problem: The miniature circuit breaker F2 or the mains supply fuse trips.

Possible cause: High inrush current due to remanence.

Remedies:

1. Disconnect all current units
2. Set the <FINE> knob in the CURRENT ADJUST block to 40 %

3. Press <ON+TIME> and turn the knob up to 100% and then down to 0%.
4. Connect one current unit. No load should be connected to it.
5. Press <ON+TIME> and set the <FINE> knob to 100%.
6. Slowly increase the COARSE adjustment to its maximum.
7. Press <OFF> and set the COARSE and FINE adjustments to 0.
8. Connect next current unit without any load connected and repeat the procedure from step 5.
 - If problem appears at step 6, try with loading some current from the unit.
 - If problem appears at step 6 for the second and third current unit, proceed with only the newly added current units connected.

9.2 Error messages

You can encounter the following error messages on the display:

Current units

Message: "Type X curr unit not installed"

Cause: You have selected 0-30/60 V in OUTPUT in order to measure current from the low-current output, but there is no low-current output on the current unit.

Remedy: Cancel the 0-30/60 V setting or connect a current unit having a low-current output.

Message: "Curr units have diff settings"

Cause: In OUTPUT, you opted to measure current from the 0-30/60 V low-current output when the switches on the current units are set differently

Remedy: Make certain the switches on the current units have the same settings.

Message: "Curr units are of diff types"

Cause: You have connected different types of current units.

Remedy: Connect current units of the same type.

9.3 Measurement errors

Problem: No reading on voltmeter and ammeter 2.

Possible cause: The instrument is not activated.

Remedy: Activate the instrument in the <V/A-METER> menu option if its indicator lamp is not lit.

Problem: Time "0.000s" is displayed but generation continues.

Possible cause: The stop condition is met but AUTO OFF is not activated.

Remedy: Press <RESET> if you want the generation time displayed.

Problem: " — A or — V" is displayed.

Cause: Because the measurement time was too short, the HOLD function cannot present any frozen readings or there was not enough time for a range to be selected automatically.

Remedy: Increase the measurement time or select a fixed range.

Problem: " — OFA or OFV" is displayed.

Cause: The magnitudes of the input signals are too great for the fixed preset range or the AUTO range does not have time to function properly for high-speed cycles. ("OF" = Overflow)

Remedy: Carry out a new measurement or select a fixed range.

Problem: "AMP2=0A AMP1=0A" is displayed.

Cause: Because the measurement current is 0, no ratio can be calculated.

Remedy: Generate current.

Problem: "** A" is displayed.**

Cause: Ammeter cannot present measured values for the generated current because:

- Current units are of different types.
- Current unit unknown because it is uncalibrated.

Remedy: Connect same type of current units or calibrate the current unit.

Problem: Unexpectedly long trip-time while testing instantaneous trip on a circuit breaker.

Remedy: Increase INT-level or use range or output with higher current rating.

10 Calibration

10.1 General

You can calibrate the zero levels (offset) for ammeter 1, ammeter 2 and the voltmeter. The timer in Oden AT is crystal controlled and requires no calibration, but can be checked against an external timer.

The instruments used for calibration should have a verified high accuracy.

The control unit and the current units must be calibrated together. It is recommended that you calibrate your Oden AT system once a year, but also if a new current unit is added to your system or if the system has been exposed to extreme variations in ambient temperature.

Regarding calibration of the scale factors we recommend that it is done at $2/3$ of the measurement range or at $2/3$ of the highest rated current for your Oden AT-system (see output specifications in chapter 11).

You can however calibrate at other values. If accuracy at a certain value is important you can calibrate at this value instead.

10.2 Calibration of offset

The zero-offset for ammeter 1, ammeter 2 and the voltmeter is calibrated.

1. Make sure that no current units are connected to the control unit and that the input for ammeter 2 is open.
2. Short circuit the voltmeter input (i.e. the voltage should be 0 V).
3. Press the <SYSTEM> button.
4. While simultaneously pressing the buttons <ESC> and <ENTER> quickly turn the <CHANGE> knob clockwise until "CALIBRATION" appears on the display. Press <ENTER> to confirm.
5. Choose "Zero-offset" and press <ENTER>.
6. Calibration of zero-offset is done automatically.

10.3 Calibration of scale factor, ammeter 1

Scale factor, range LOW

1. Press the <AMMETER> menu-option and change the range to "LOW". Press <ENTER> to confirm, then press <AMMETER> to leave the menu.
2. Connect a reference ammeter to the current output.

Note: *If a current transformer is used, make sure that it is applied at least 0.5 meter from any bend of the current conductor. Other conductors shall not be closer than 0.5 meter from the current transformer.*

3. Activate the HOLD-function by pressing <HOLD>. The lamp in the HOLD-button lights up.
4. Press the <MOM ON> button and adjust the current until the calibration value (about 2/3 of maximal current, see chapter 11 Specifications, section 11.2 -11.5) appears on the reference ammeter. Release the <MOM ON> button when the value is adjusted.

Note: *The lamp on the <HOLD>-button should be flashing.*

5. Press the SYSTEM menu option.
6. While simultaneously pressing the buttons <ESC> and <ENTER> quickly turn the <CHANGE> knob clockwise, until "CALIBRATION" appears on the display. Press <ENTER> to confirm.
7. Choose "AMMETER 1" and press <ENTER>.
8. Turn the <CHANGE> knob until the current value on the display matches that on the reference ammeter. Press <ENTER> to confirm the calibration.

Scale factor, range HIGH

1. Press the <AMMETER> menu-option and change the range to "HIGH". Press <ENTER> to confirm and then <AMMETER> to leave the menu.
2. The rest of the procedure is the same as step 2 - 8 in the "LOW"-range.

10.4 Scale factor for the I/30-function.

1. See that the I/30-function is turned off.
2. Activate the HOLD-function by pressing <HOLD> (the LED in the button lights up).
3. Press the <MOM ON> button and hold it down for a second. The LED in the HOLD-button should start flashing.
4. Note the current value for ammeter 1 that is displayed on the display.
5. Activate the I/30-function.
6. Press the <MOM ON> button and hold it down for a second. The LED in the HOLD-button should start flashing.
7. Press the <SYSTEM> menu option.
8. While simultaneously pressing the buttons <ESC> and <ENTER> quickly turn the <CHANGE> knob clockwise until "CALIBRATION" appears on the display. Press <ENTER> to confirm.
9. Choose "AMMETER 1" and press <ENTER>. "I/30" is displayed in the upper right corner of the display.
10. Turn the <CHANGE> knob until the current value on the display matches the value from the previous measurement in step 4. Press <ENTER> to confirm the calibration.

The I/30 function is intended only for use at coarse adjustment of high currents and gives only an approximate indication.

10.5 Calibration of scale factor, ammeter 2

Scale factor, range 0 – 2 A

1. Press the <V/A METER> menu option, select "AMMETER 2" and press <ENTER>.
2. Select the "0 – 2 A"-range and press <ENTER>. Press <V/A METER> to leave the menu.
3. Connect an AC current source and a reference AC ammeter to the AMMETER 2 input.
4. Adjust the current from the AC current source to 1.3 A (2/3 of the full range).
5. Activate the HOLD-function.
6. Press the <MOM ON> button and hold it down for a second. The LED in the HOLD-button should start flashing.
7. Press the <SYSTEM> menu option.
8. While simultaneously pressing the buttons <ESC> and <ENTER> quickly turn the <CHANGE> knob clockwise until "CALIBRATION" appears on the display. Press <ENTER> to confirm.
9. Choose "AMMETER 2" and press <ENTER>.
10. Turn the <CHANGE> knob until the current value on the display matches that on the reference ammeter. Press <ENTER> to confirm the calibration.

Scale factor, range 0 – 20 A

1. Press the <V/A METER> menu option, select "AMMETER 2" and press <ENTER>.
2. Select the "0 – 20 A"-range and press <ENTER>. Press <V/A METER> to leave the menu.
3. The rest of the process is just the same as for the 0 – 2 A-range, follow step 3 to 10. Calibrate at 13 A (2/3 of the full range).

10.6 Calibration of scale factor, voltmeter

Scale factor, range 0 – 0.2 V

1. Press the <V/A METER> menu option, select "VOLTMETER" and press <ENTER>.
2. Select the "0 – 0.2 V"-range and press <ENTER>. Press <V/A METER> to leave the menu.
3. Connect a DC voltage source and a reference DC voltmeter to the VOLTMETER input.
4. Adjust the voltage from the DC voltage source to about 0.133 V (2/3 of the full range).
5. Activate the HOLD-function.
6. Press the <MOM ON> button and hold it down for a second. The LED in the HOLD-button should start flashing.
7. Press the <SYSTEM> menu option.
8. While simultaneously pressing the buttons <ESC> and <ENTER> quickly turn the <CHANGE> knob clockwise until "CALIBRATION" appears on the display. Press <ENTER> to confirm.
9. Choose "VOLTMETER" and press <ENTER>.
10. Turn the <CHANGE> knob until the voltage value on the display matches that on the reference ammeter. Press <ENTER> to confirm the calibration.

Scale factor, ranges 0 – 2 V, 0 – 20 V and 0 – 200 V

1. Press the <V/A METER> menu option, select "VOLTMETER" and press <ENTER>.
2. Select the range that should be calibrated (0 – 2 V, 0 – 20 V or 0 – 200 V) and press <ENTER>. Press <V/A METER> to leave the menu.
3. The rest of the process is just the same as for the 0 – 0.2 V range, follow step 3 to 10. Calibrate at about 2/3 of the full range; 1.333 V for the 0 – 2 V range, 13.33 V for the 0 – 20 V range and 133.3 V for the 0 – 200 V-range.

10.7 Resetting to preset (standardized) calibration values

Instead of regular calibration a resetting function can be activated that will set the calibration values to a set of preset and standardized values. This will give an accuracy of about 1%. Resetting can never replace a regular calibration where accurate and traceable reference instrument are used, but is a quick and simple method of solving the problem of having no calibration values at all. Resetting must always be followed by a calibration of the zero-off-set, which is a part of the regular calibration procedure.

It is possible to combine resetting and calibration; first perform a reset and then calibrate the ranges for which required instruments and sources are available. The ranges that can not be calibrated will then use the standard calibration values.

Note: *When a reset is performed, ALL settings, values and parameters will be set to preset default values. This also implies the settings stored in Oden AT's memories, which will be lost if a reset is performed.*

Performing a reset

1. Press down the <RESET> button while Oden AT is switched on.

11 Specifications

11.1 General

Specifications are valid for an ambient temperature of +25°C and nominal input voltage. The specifications are subject to change without further notice.

System designation

An ODEN AT-system consists of a control unit and one, two or three current units. There are three different versions of the current units: S-unit (standard), X-unit (extra 30/60 V outlet) and H-unit (high current). The system designation indicates the number and version of current units included.

Example: ODEN AT/2X

2 = Number of current units

X = Version of current unit (S, X or H)

Environment

<i>Application field</i>	The instrument is intended for use in medium-voltage substations and industrial environments.
<i>Temperature</i>	
<i>Operating</i>	0°C to +50°C (+32°F to +122°F)
<i>Storage & transport</i>	-25°C to +55°C (-13°F to +127°F)
<i>Humidity</i>	5% - 95% RH, Non-condensing.

CE-marking

LVD	Low Voltage Directive 73/23/ EEC am. by 93/68/EEC
EMC	EMC Directive 89/336/EEC am. by 91/263/EEC, 92/31/EEC and 93/68/EEC

General

<i>Mains voltage</i>	<ul style="list-style-type: none"> • 240 V AC 50/60 Hz • 400 V AC 50/60 Hz • 480 V AC 60 Hz The mains voltage must be between -14% and +10% of the nominal input voltage stated
<i>Mains inlet</i>	IEC 60309-2, 63 A
<i>Power consumption</i>	The power consumption for Oden AT depends on the generated output current, see sections 11.2, 11.4 and 11.6 for details.
<i>Input current</i>	Output current x open circuit voltage / input voltage
<i>Protection</i>	The output transformer has a built-in thermal cut-out, and the primary side is protected by a miniature circuit breaker
<i>Dimensions</i>	
<i>Control unit AT</i>	570 x 310 x 230 mm (22.4" x 12.2" x 9")
<i>Current unit S, X H</i>	570 x 310 x 155 mm (22.4" x 12.2" x 6")
<i>Weight</i>	
<i>Control unit AT</i>	25 kg (55 lbs)
<i>Current unit S</i>	42 kg (92.6 lbs)
<i>Current unit X</i>	45 kg (99.3 lbs)
<i>Current unit H</i>	49 kg (108 lbs)

Display

<i>Type</i>	LCD
<i>Available languages</i>	English, German, French, Spanish, Swedish.

Measurement section

Ammeters

<i>Measurement method</i>	AC, true RMS
<i>Inaccuracy</i>	1% of range ±1 digit

Ammeter 1

<i>Ranges</i>	0 - 4800 A / 0 -15 kA 0 - 9600 A / 0 - 30 kA 0 - 960 A / 0 - 3 kA
---------------	---

Ammeter 2

<i>Ranges</i>	0 - 2.000 A / 0 - 20.00 A
<i>Maximum current</i>	20 A (The input is not protected by a fuse)
<i>Dielectric withstand</i>	Galvanically isolated

Voltmeter

<i>Measurement method</i>	AC, true RMS
<i>Ranges</i>	0 - 0.2 V, 0 - 2 V, 0 - 20 V, 0 - 200 V, AUTO
<i>Inaccuracy</i>	1% of range ±1 digit
<i>Input resistance (R_{in})</i>	240 kΩ (range 0 - 200 V) 24 kΩ (other ranges)
<i>Dielectric withstand</i>	2.5 kV

Timer

<i>Presentation</i>	In seconds, mains frequency cycles or hours and minutes
<i>Ranges</i>	0.000 - 99999.9 s 0 - 9999 cycles 0.001s - 99 h 59 min
<i>Inaccuracy</i>	±(1 digit + 0.01% of value) For the stop condition in INT-mode 1 ms shall be added to the specified measurement error.

Stop input

<i>Max. input voltage</i>	250 V AC / 275 V DC
---------------------------	---------------------

Phase angle

<i>Range</i>	0 - 359°
<i>Resolution</i>	1°
<i>Accuracy</i>	±2° (For voltage and current readings that are higher than 10% of the selected range)

Z, P, R, X, S, Q and power factor (cos φ)

For these measurements the result is calculated using two or three items. The accuracy depends on the errors for the items included (U, I and sometimes φ).

I_{max}

Stores highest current value that exists ≥100 ms

INT-level

Threshold indicating that current is interrupted, can be set to 0.7 or 2.1% of range for Ammeter 1

11.2 Output specifications for 240 V Oden AT systems at 50 Hz

Specifications are valid at nominal input voltage and ambient temperature +25 °C, (77 °F) and with the current adjustment set to 100%. The specified times refer to the maximum loading time during a single load period, they are not valid during repeated use.

Important

Exceeding the currents and load times specified could cause damage to the equipment.

The specified output voltage is the voltage at the output terminals. The voltage drop in the current cables and connections between current units in series is not included.

Nominal input voltage: 240 V AC

Oden AT/1S (240 V)

OUTPUT HIGH I

Output (A)	Voltage (V)	Time on
0	6.0	Continuous
1000	5.3	Continuous
2000	4.6	3 min
3000	3.9	1 min
4000	3.2	40 sec
5000	2.5	30 sec
6000	2.0	20 sec
7000	1.3	3 sec

Input current: Output current/40 (approximate)

Oden AT/2S (240 V)

OUTPUT HIGH I - Units in PARALLEL

Output (A)	Voltage (V)	Time on
0	6.0	Continuous
1000	5.6	Continuous
2000	5.3	Continuous
3000	5.0	8 min
4000	4.6	2 min
6000	3.9	60 sec
8000	3.2	3 sec

Input current: Output current/40 (approximate)

OUTPUT HIGH I - Units in SERIES

Output (A)	Voltage (V)	Time on
0	12.0	Continuous
1000	10.5	Continuous
2000	9.0	3 min
3000	7.6	1 min
4000	6.0	3 sec

Input current: Output current/20 (approximate)

Oden AT/3S (240 V)

OUTPUT HIGH I - Units connected in PARALLEL

Output (A)	Voltage (V)	Time on
0	6.0	Continuous
1000	5.8	Continuous
2000	5.5	Continuous
2500	5.4	Continuous
4000	5.1	8 min
6000	4.6	2 min
8000	4.2	3 sec

Input current: Output current/40

OUTPUT HIGH I - Units in SERIES

Output (A)	Voltage (V)	Time on
0	18.0	Continuous
840	16.1	Continuous
1000	15.9	30 min
2000	13.7	2 min
2600	12.4	3 sec

Input current: Output current/13 (approximate)

Oden AT/1X (240 V)

OUTPUT HIGH I

See section 11.2 Oden AT/1S (240 V)

OUTPUT 0 – 30 V/60 V - Switch pos: 0 – 30 V

Output (A)	Voltage (V)	Time on
0	30	Continuous
160	27	Continuous
300	25	3 min
600	21	12 sec
1200	8	2 sec

Input current: Output current/8 (approximate)

OUTPUT 0 – 30 V/60 V - Switch pos: 0 – 60 V

Output (A)	Voltage (V)	Time on
0	60	Continuous
80	55	Continuous
150	50	3 min
300	40	12 sec
600	17	2 sec

Input current: Output current/4 (approximate)

Oden AT/2X (240 V)

OUTPUT HIGH I

See section 11.2 Oden AT/2S (240 V)

**OUTPUT 0 – 30 V/60 V - Switch pos: 0 – 30 V
Units in PARALLEL**

Output (A)	Voltage (V)	Time on
0	30	Continuous
320	28	Continuous
600	25	3 min
1200	20	12 sec
1600	17	2 sec

Input current: Output current/8 (approximate)

**OUTPUT 0 – 30 V/60 V - Switch pos: 0 – 30 V
Units in SERIES**

Output (A)	Voltage (V)	Time on
0	60	Continuous
160	54	Continuous
300	50	3 min
600	40	12 sec
800	33	2 sec

Input current: Output current/4 (approximate)

**OUTPUT 0 – 30 V/60 V - Switch pos: 0– 60 V
Units in SERIES**

Output (A)	Voltage (V)	Time on
0	120	Continuous
80	110	Continuous
150	100	3 min
300	82	12 sec
400	67	1 sec

Input current: Output current/2 (approximate)

Oden AT/3X (240 V)**OUTPUT HIGH I**

See section 11.2 Oden AT/3S (240 V)

**OUTPUT 0 – 30 V/60 V - Switch pos: 0 – 30 V
Units in PARALLEL**

Output (A)	Voltage (V)	Time on
0	30	Continuous
480	27	Continuous
600	26	4 min
1200	23	1 min
1600	21	3 sec

Input current: Output current/8 (approximate)

**OUTPUT 0 – 30 V/60 V - Switch pos: 0 – 30 V
Units in SERIES**

Output (A)	Voltage (V)	Time on
0	90	Continuous
160	82	Continuous
300	75	3 min
500	65	3 sec

Input current: Output current/2.7 (approximate)

**OUTPUT 0 – 30 V/60 V - Switch pos: 0 – 60 V
Units in SERIES**

Output (A)	Voltage (V)	Time on
0	180	Continuous
80	165	Continuous
150	150	3 min
250	125	3 sec

Input current: Output current/1.3 (approximate)

Oden AT/1H (240 V)**OUTPUT HIGH I**

Output (A)	Voltage (V)	Time on
0	3.6	Continuous
1000	3.4	Continuous
1250	3.4	Continuous
2000	3.2	5 min
3000	3.0	2 min
4000	2.8	1 min 30 sec
5000	2.6	1 min
6000	2.4	40 sec
8000	1.9	20 sec
10000	1.5	12 sec
11000	1.3	5 sec

Input current: Output current/66 (approximate)

Oden AT/2H (240 V)**OUTPUT HIGH I - Units in PARALLEL**

Output (A)	Voltage (V)	Time on
0	3.6	Continuous
2000	3.4	Continuous
2500	3.4	Continuous
4000	3.2	5 min
6000	3.0	2 min
8000	2.8	1 min 30 sec
10000	2.6	1 min
13000	2.2	2 sec

Input current: Output current/66 (approximate)

OUTPUT HIGH I - Units in SERIES

Output (A)	Voltage (V)	Time on
0	7.3	Continuous
1250	6.7	Continuous
2000	6.3	5 min
3000	5.9	2 min
4000	5.4	1 min
6000	4.4	5 sec

Input current: Output current/33 (approximate)

Oden AT/3H (240 V)**OUTPUT HIGH I - Units in PARALLEL**

Output (A)	Voltage (V)	Time on
0	3.6	Continuous
2000	3.5	Continuous
3800	3.4	Continuous
6000	3.2	5 min
8000	3.1	3 min
10000	2.9	1 min 30 sec
13000	2.7	2 sec

Input current: Output current/66 (approximate)

OUTPUT HIGH I - Units in SERIES

Output (A)	Voltage (V)	Time on
0	11.0	Continuous
1250	10.0	Continuous
2000	9.5	5 min
3000	8.7	2 min
4300	7.8	2 sec

Input current: Output current/22 (approximate)

11.3 Load curves, Oden AT systems for 240 V

OUTPUT HIGH I, Oden AT systems for 240 V at 50/60 Hz operation

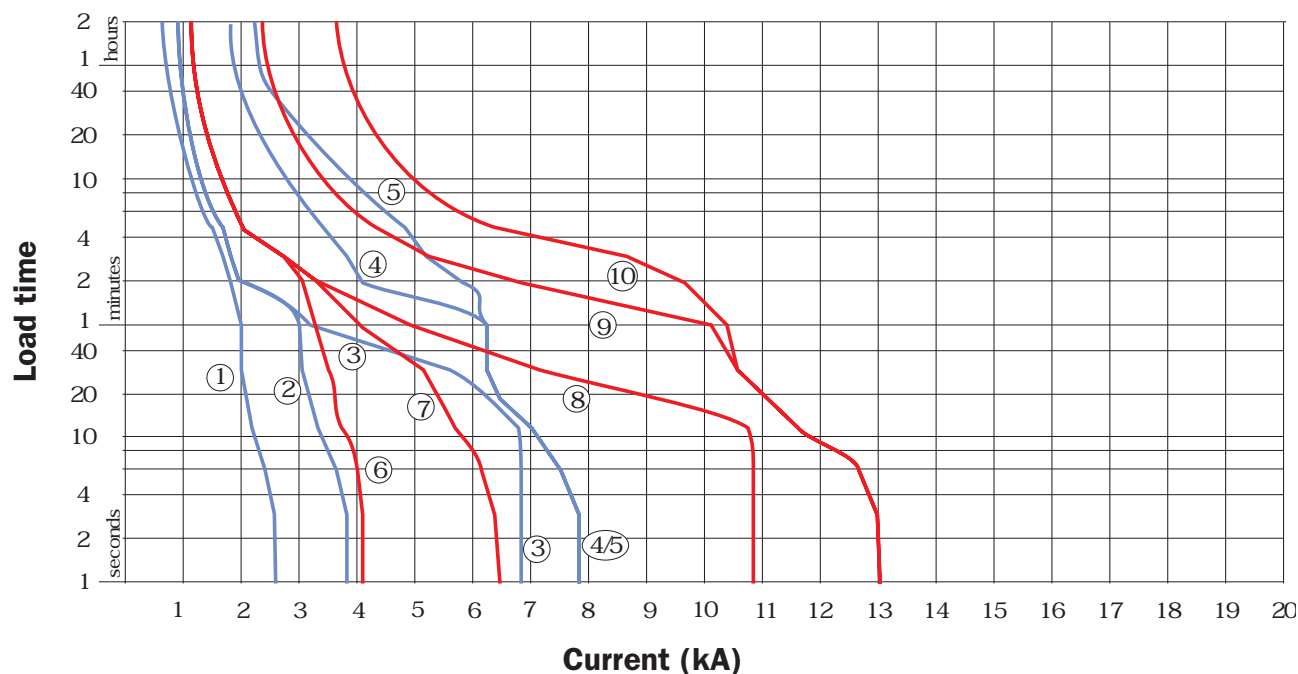

Oden AT/3S, units in SERIES	1	Oden AT/3H, units in SERIES	6
Oden AT/2S, units in SERIES	2	Oden AT/2H, units in SERIES	7
Oden AT/1S	3	Oden AT/1H	8
Oden AT/2S, units in PARALLEL	4	Oden AT/2H, units in PARALLEL	9
Oden AT/3S, units in PARALLEL	5	Oden AT/3H, units in PARALLEL	10

Note: The curves for systems with type S units are also valid for systems equipped with units of type X.

OUTPUT HIGH I, Oden AT systems for 240 V

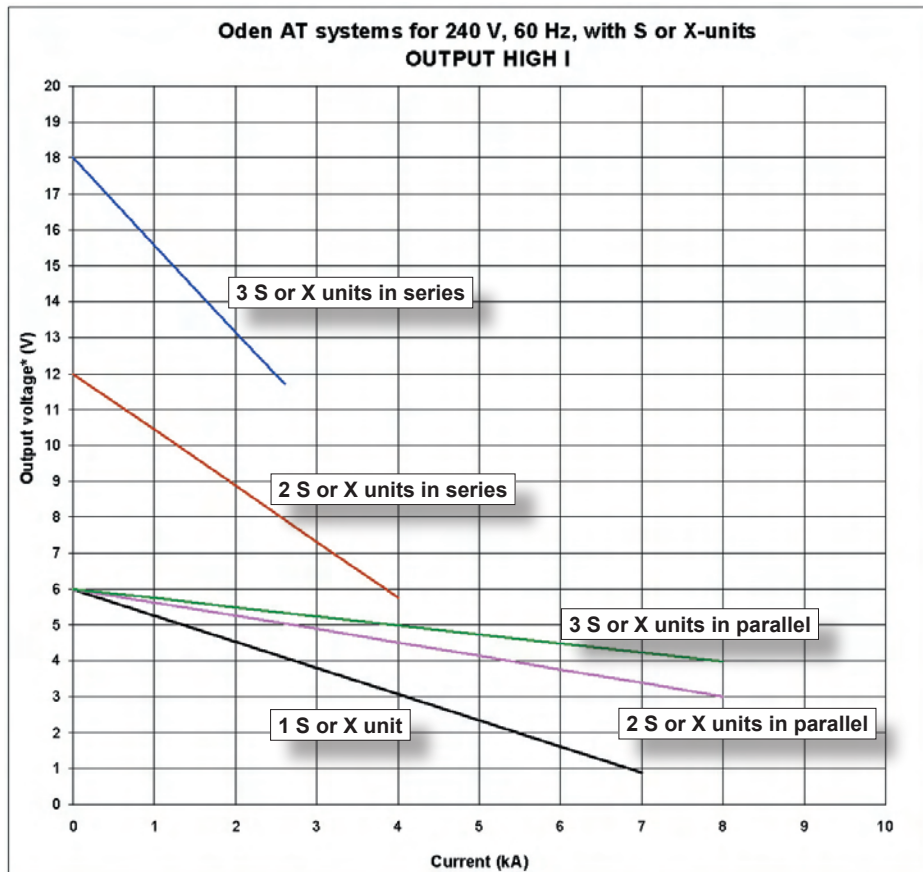
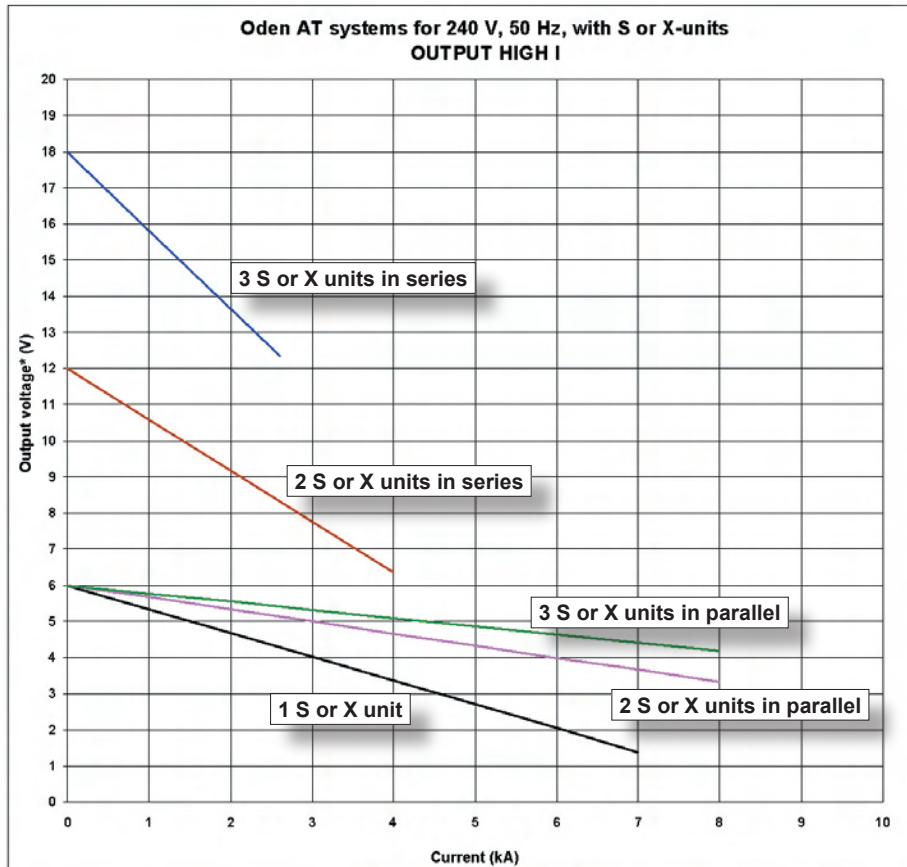

* Voltage between the output terminals.

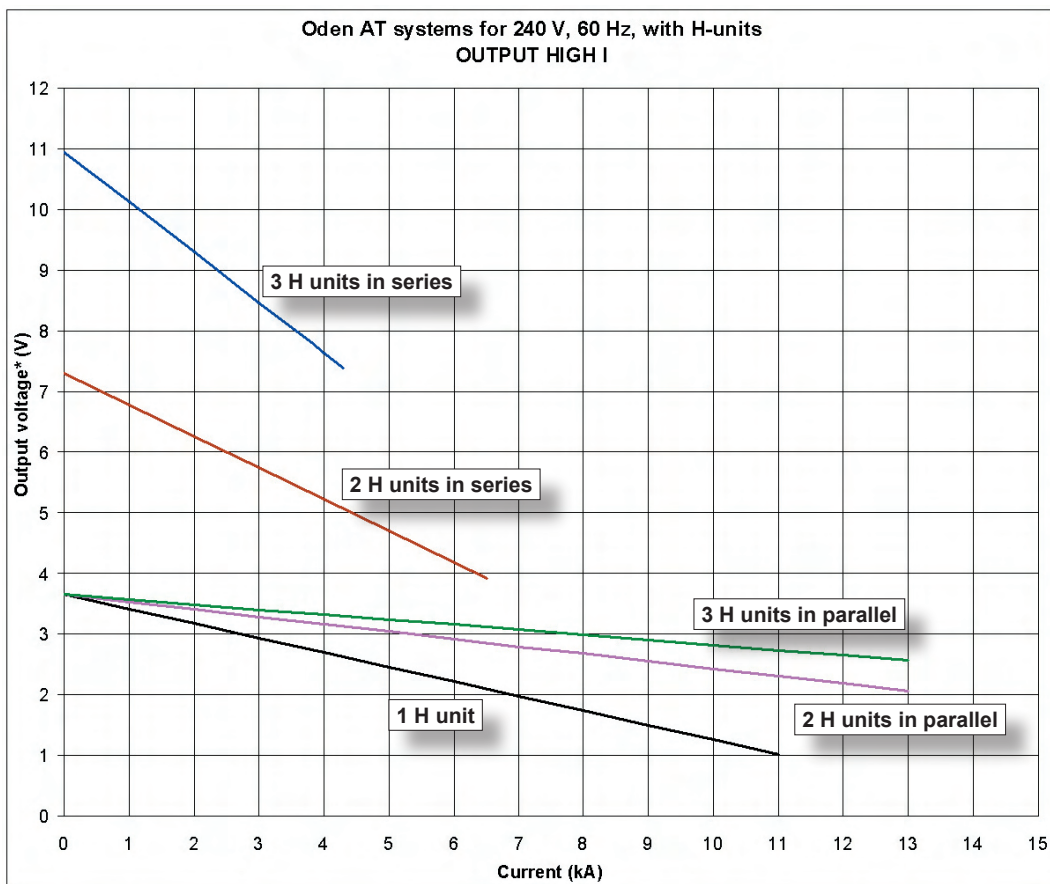
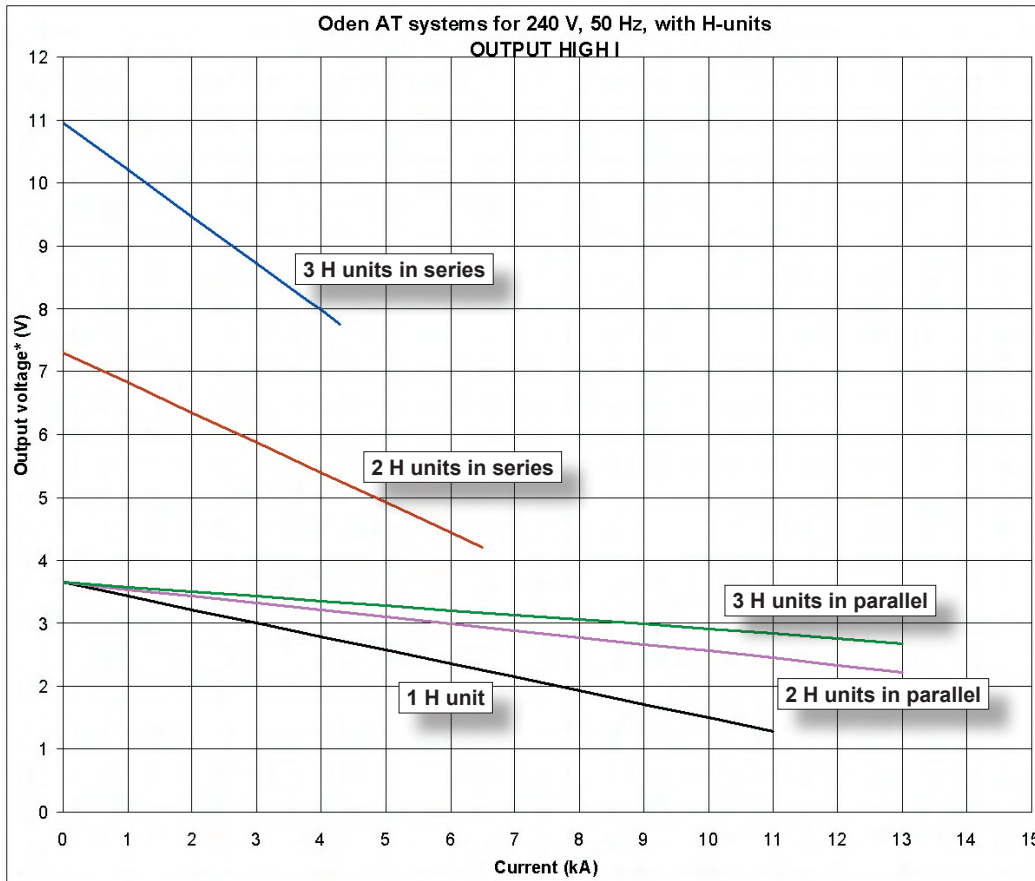

* Voltage between the output terminals.

OUTPUT 0-30V/60V, Oden AT systems for 240 V at 50/60 Hz operation

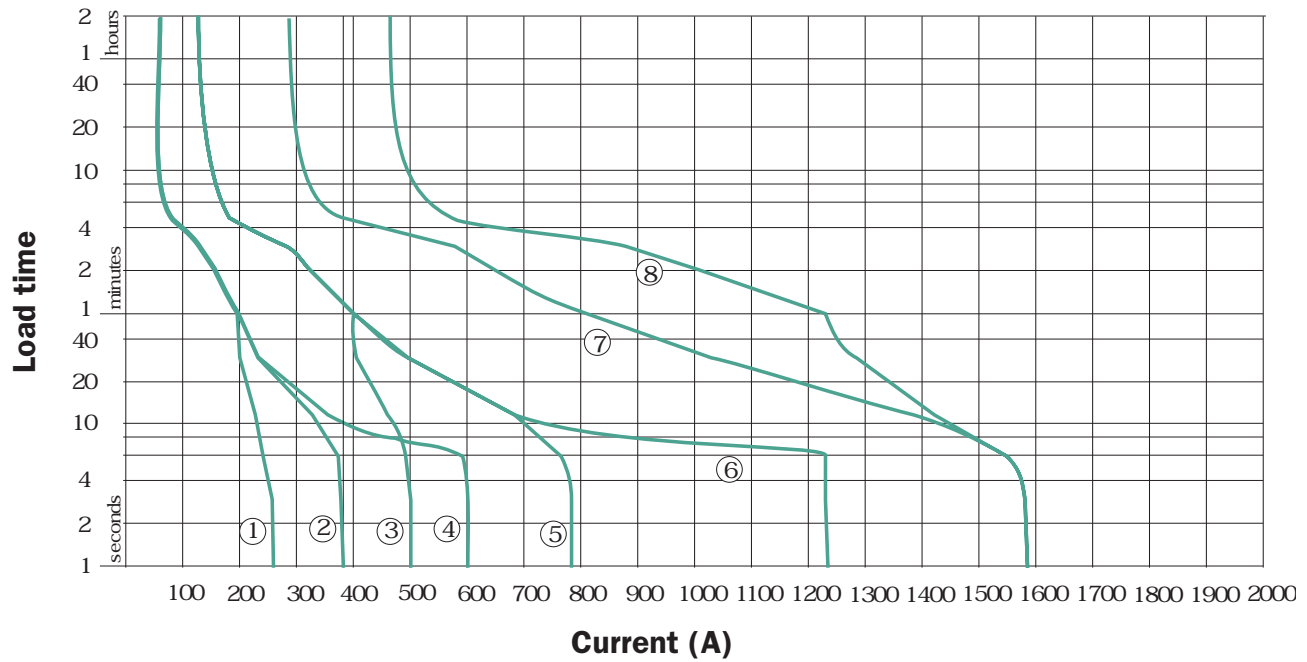

Oden AT/3X	60 V, SERIES	1
Oden AT/2X	60 V, SERIES	2
Oden AT/3X	30 V, SERIES	3
Oden AT/1X	60 V range	4
Oden AT/2X	30 V, SERIES	5
Oden AT/1X	30 V range	6
Oden AT/2X	30 V, PARALLEL	7
Oden AT/3X	30 V, PARALLEL	8

OUTPUT 0-30V/60V, Oden AT systems for 240 V at 50 Hz operation

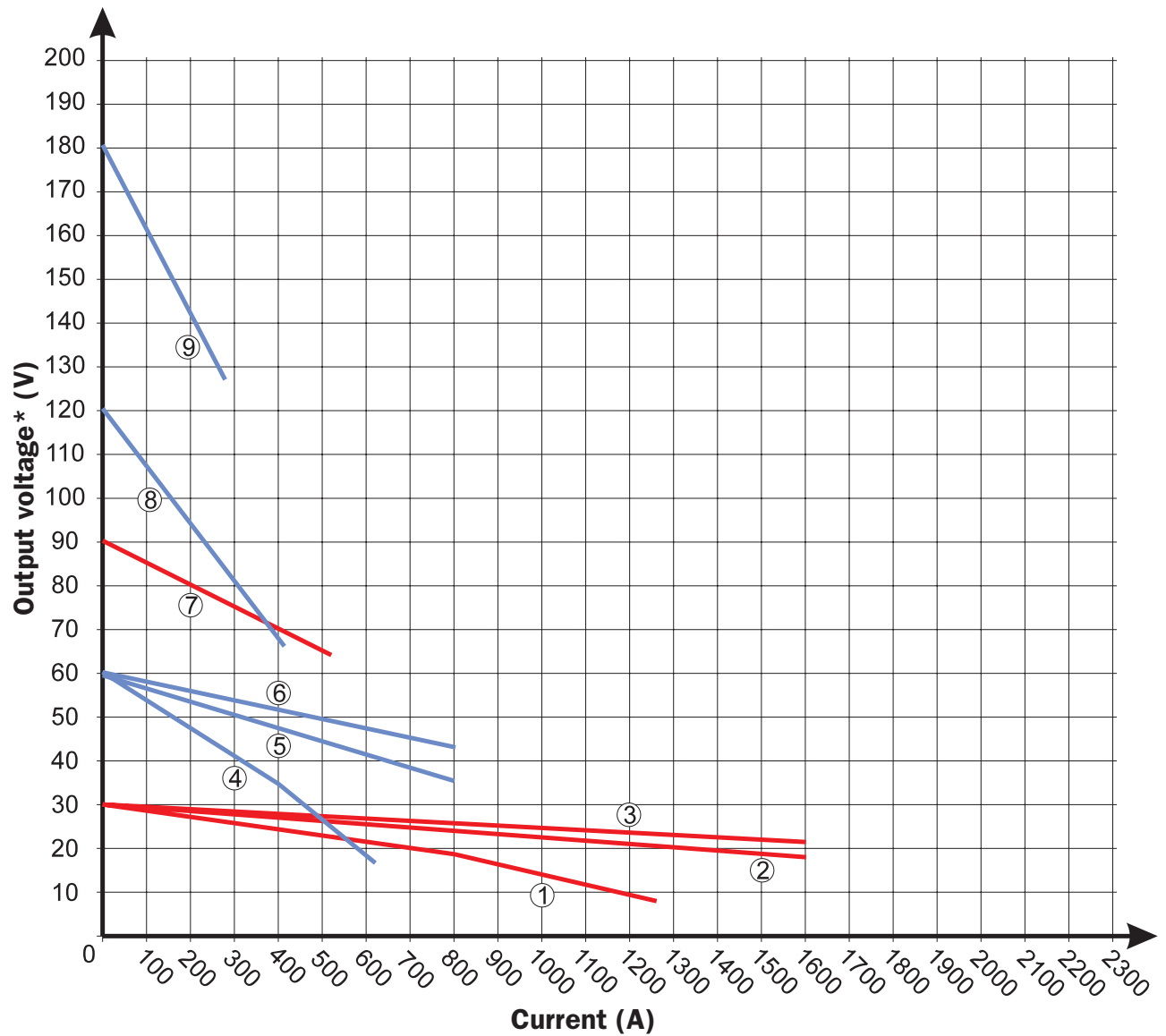

Oden AT/1X	30 V range	1
Oden AT/2X	30 V, PARALLEL	2
Oden AT/3X	30 V, PARALLEL	3
Oden AT/1X	60 V range	4
Oden AT/2X	30 V, SERIES	5
Oden AT/3X	60 V, PARALLEL	6
Oden AT/3X	30 V, SERIES	7
Oden AT/2X	60 V, SERIES	8
Oden AT/3X	60 V, SERIES	9

* Voltage between the output terminals.

11.4 Output specifications for 400 V Oden AT systems at 50 Hz

Specifications are valid at nominal input voltage and ambient temperature +25°C, (77°F) and with the current adjustment set to 100%. The specified times refer to the maximum loading time during a single load period, they are not valid during repeated use.

Important

Exceeding the currents and load times specified could cause damage to the equipment.

The specified output voltage is the voltage at the output terminals. The voltage drop in the current cables and connections between current units in series is not included.

Nominal input voltage: 400 V AC

Oden AT/1S (400 V)

OUTPUT HIGH I

Output (A)	Voltage (V)	Time on
0	6.0	Continuous
1000	5.3	Continuous
2000	4.6	3 min
3000	3.9	1 min
4000	3.2	40 sec
5000	2.5	30 sec
6000	2.0	20 sec
7000	1.3	3 sec

Input current: Output current/66 (approximate)

Oden AT/2S (400 V)

OUTPUT HIGH I - Units in PARALLEL

Output (A)	Voltage (V)	Time on
0	6.0	Continuous
1000	5.6	Continuous
1900	5.3	Continuous
3000	5.0	10 min
4000	4.6	3 min
6000	3.9	30 sec
8000	3.2	10 sec
10000	2.7	6 sec
13000	1.6	3 sec

Input current: Output current/66 (approximate)

OUTPUT HIGH I - Units in SERIES

Output (A)	Voltage (V)	Time on
0	12.0	Continuous
900	10.6	Continuous
2000	9.0	3 min
3000	7.6	30 sec
4000	6.0	10 sec
6000	3.1	3 sec

Input current: Output current/33 (approximate)

Oden AT/3S (400 V)

OUTPUT HIGH I - Units in PARALLEL

Output (A)	Voltage (V)	Time on
0	6.0	Continuous
1000	5.8	Continuous
1900	5.5	Continuous
3000	5.3	10 min
4000	5.1	3 min
6000	4.6	30 sec
8000	4.2	10 sec
10000	3.7	6 sec
13000	3.2	3 sec

Input current: Output current/66 (approximate)

OUTPUT HIGH I - Units in SERIES

Output (A)	Voltage (V)	Time on
0	18.0	Continuous
600	16.8	Continuous
1000	15.9	30 min
2000	13.7	40 sec
3000	11.5	8 sec
4000	9.4	3 sec

Input current: Output current/22 (approximate)

Oden AT/1X (400 V)

OUTPUT HIGH I

See section 11.4. Oden AT/1S (400 V)

OUTPUT 0 – 30 V/60 V - Switch pos: 0 – 30 V

Output (A)	Voltage (V)	Time on
0	30	Continuous
160	27	Continuous
300	25	3 min
600	21	12 sec
800	17	8 sec
1200	8	2 sec

Input current: Output current/13 (approximate)

OUTPUT 0 – 30 V/60 V - Switch pos: 0 – 60 V

Output (A)	Voltage (V)	Time on
0	60	Continuous
80	55	Continuous
150	50	3 min
300	40	12 sec
400	33	8 sec
600	17	2 sec

Input current: Output current/6.7 (approximate)

Oden AT/2X (400 V)

OUTPUT HIGH I

See section 11.4. Oden AT/2S (400 V)

Oden AT/3X (400 V)

OUTPUT HIGH I

See section 11.4 Oden AT/3S (400 V)

**OUTPUT 0 – 30 V/60 V - Switch pos: 0 – 30 V
Units in PARALLEL**

Output (A)	Voltage (V)	Time on
0	30	Continuous
320	28	Continuous
600	25	2 min
1200	20	15 sec
1600	17	8 sec
2000	12	5 sec

Input current: Output current/13 (approximate)

**OUTPUT 0 – 30 V/60 V - Switch pos: 0 – 30 V
Units in SERIES**

Output (A)	Voltage (V)	Time on
0	90	Continuous
120	84	Continuous
300	75	1 min 30 sec
500	66	12 sec
700	56	5 sec
800	51	3 sec

Input current: Output current/4.5 (approximate)

**OUTPUT 0 – 30 V/60 V - Switch pos: 0 – 30 V
Units in SERIES**

Output (A)	Voltage (V)	Time on
0	60	Continuous
160	54	Continuous
300	50	3 min
600	40	12 sec
800	33	8 sec
1200	17	3 sec

Input current: Output current/6.7 (approximate)

**OUTPUT 0 – 30 V/60 V - Switch pos: 0 – 60 V
Units in SERIES**

Output (A)	Voltage (V)	Time on
0	180	Continuous
60	168	Continuous
145	152	3 min
200	142	30sec
300	122	8 sec
400	104	3 sec

Input current: Output current/2.2 (approximate)

**OUTPUT 0 – 30 V/60 V - Switch pos: 0 – 60 V
Units in SERIES**

Output (A)	Voltage (V)	Time on
0	120	Continuous
80	110	Continuous
150	100	3 min
300	82	12 sec
400	67	8 sec
600	37	2 sec

Input current: Output current/3.3 (approximate)

Oden AT/1H (400 V)

OUTPUT HIGH I

Output (A)	Voltage (V)	Time on
0	3.6	Continuous
1000	3.4	Continuous
1250	3.4	Continuous
2000	3.2	5 min
3000	3.0	2 min
4000	2.8	1 min 30 sec
5000	2.6	1 min
6000	2.4	40 sec
8000	1.9	20 sec
10000	1.5	12 sec
11000	1.3	5 sec

Input current: Output current/110 (approximate)

Oden AT/2H (400 V)**OUTPUT HIGH I - Units in PARALLEL**

Output (A)	Voltage (V)	Time on
0	3.6	Continuous
2000	3.4	Continuous
2500	3.4	Continuous
4000	3.2	5 min
6000	3.0	2 min
8000	2.8	1 min 30 sec
10000	2.6	1 min
13000	2.2	20 sec
17000	1.8	10 sec
21000	1.4	3 sec

Input current: Output current/110 (approximate)

OUTPUT HIGH I - Units in SERIES

Output (A)	Voltage (V)	Time on
0	7.3	Continuous
1250	6.7	Continuous
2000	6.3	5 min
3000	5.9	2 min
4000	5.4	1 min 30 sec
6000	4.5	30 sec
8000	3.5	10 sec
10000	2.5	5 sec

Input current: Output current/55 (approximate)

Oden AT/3H (400V)**OUTPUT HIGH I - Units in PARALLEL**

Output (A)	Voltage (V)	Time on
0	3.6	Continuous
2000	3.5	Continuous
3800	3.4	Continuous
6000	3.2	5 min
8000	3.1	2 min
10000	3.0	1 min
13000	2.7	20 sec
17000	2.4	10 sec
21000	2.1	3 sec

Input current: Output current/110 (approximate)

OUTPUT HIGH I - Units in SERIES

Output (A)	Voltage (V)	Time on
0	11.0	Continuous
1250	10.0	Continuous
2000	9.5	5 min
3000	8.7	2 min
4000	8.0	30 sec
5000	7.2	10 sec
6000	6.5	8 sec
7000	5.8	5 sec

Input current: Output current/37 (approximate)

11.5 Load curves, Oden AT systems for 400 V

OUTPUT HIGH I, Oden AT systems for 400 V 50/60 Hz and 480 V 60 Hz

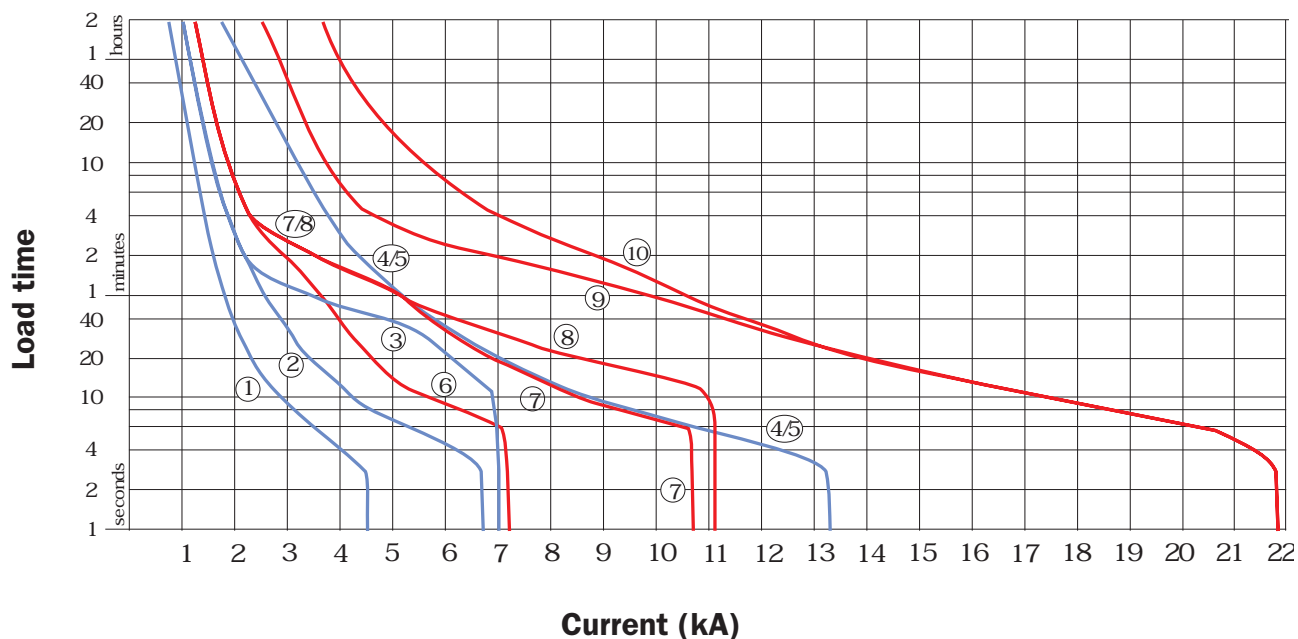

Oden AT/3S	units in SERIES	1	Oden AT/3H	units in SERIES	6
Oden AT/2S	units in SERIES	2	Oden AT/2H	units in SERIES	7
Oden AT/1S		3	Oden AT/1H		8
Oden AT/2S	units in PARALLEL	4	Oden AT/2H	units in PARALLEL	9
Oden AT/3S	units in PARALLEL	5	Oden AT/3H	units in PARALLEL	10

Note: The curves for systems with type S units are also valid for systems equipped with units of type X.

OUTPUT HIGH I, Oden AT systems for 400 V

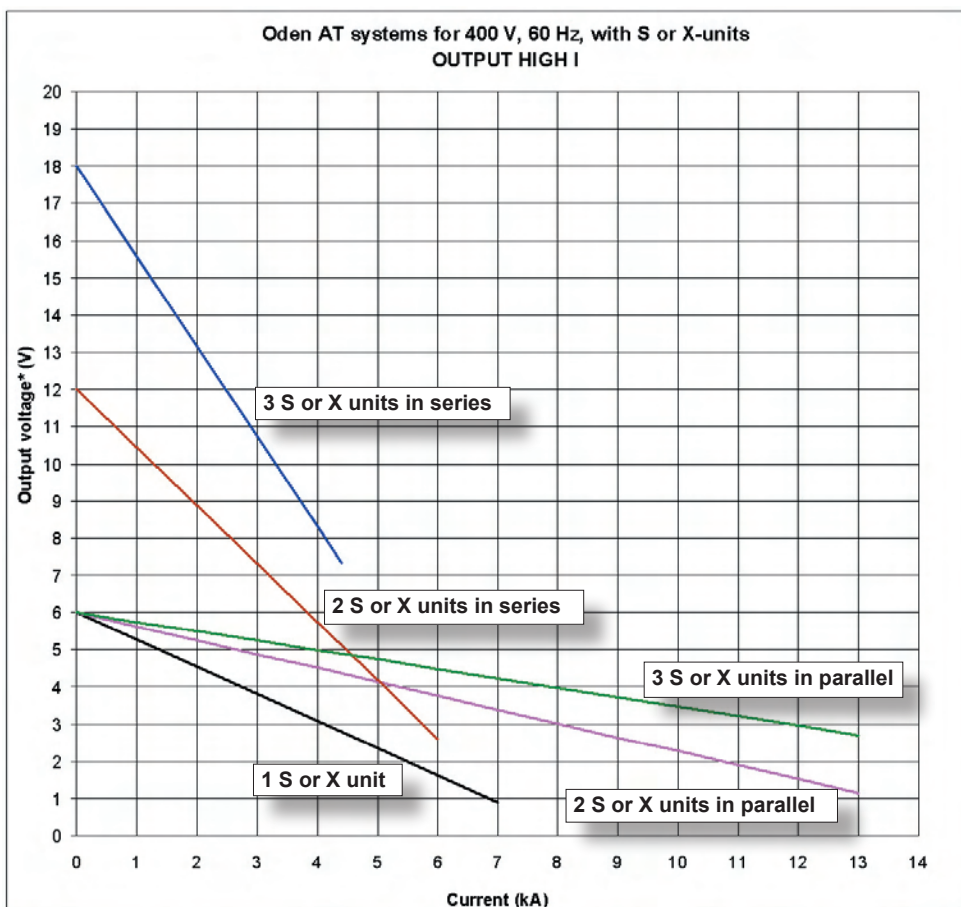
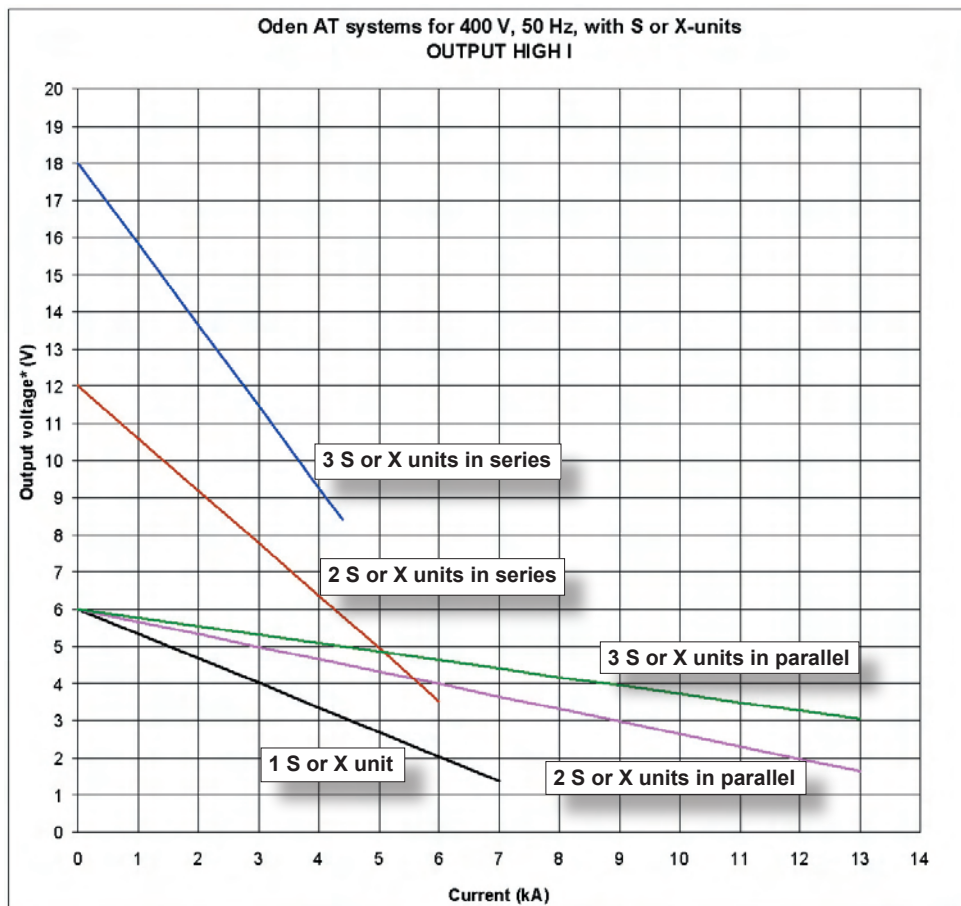

* Voltage between the output terminals.

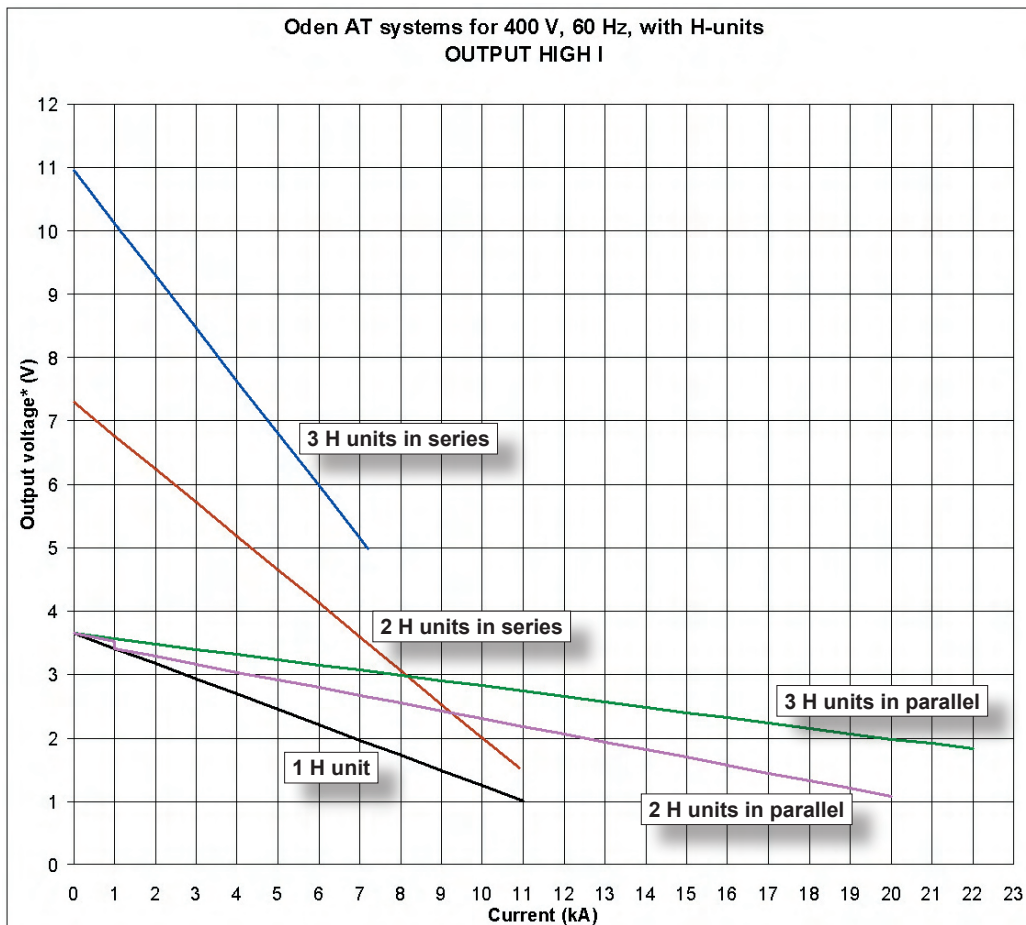
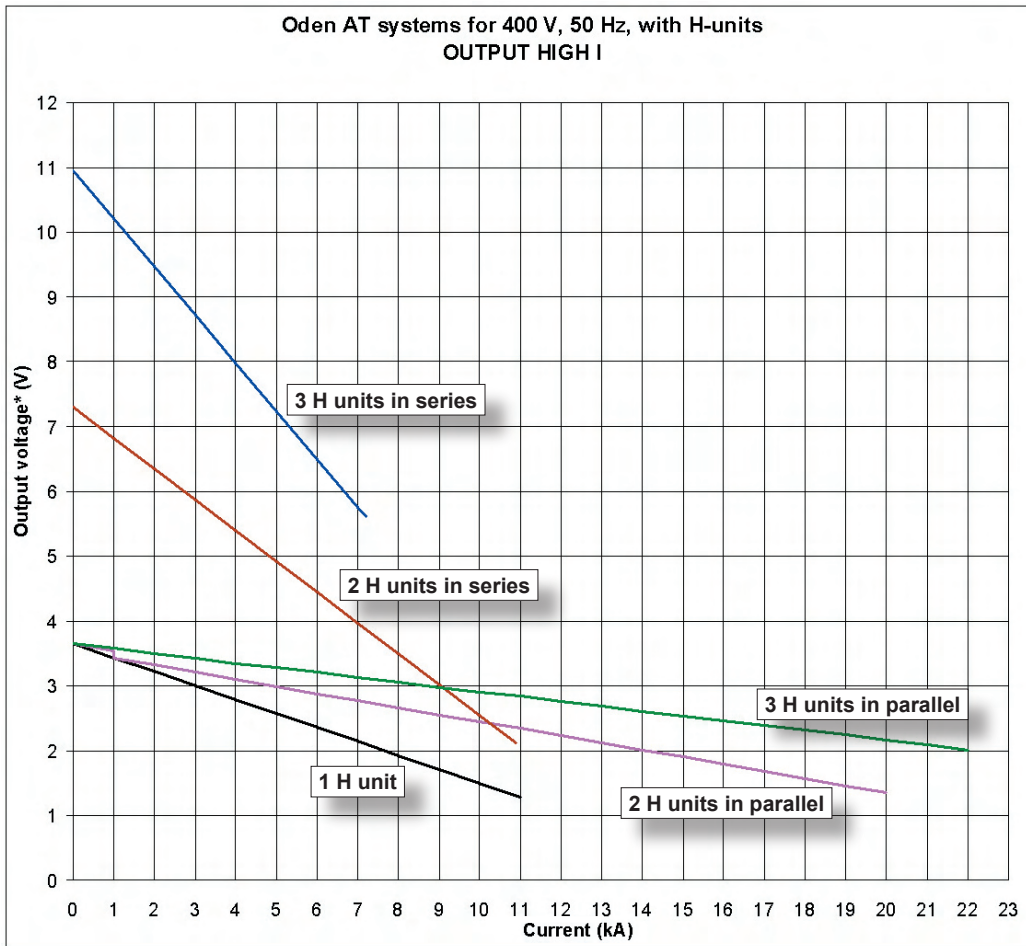

* Voltage between the output terminals.

OUTPUT 0 – 30 V/60 V, Oden AT systems for 400 V 50 Hz

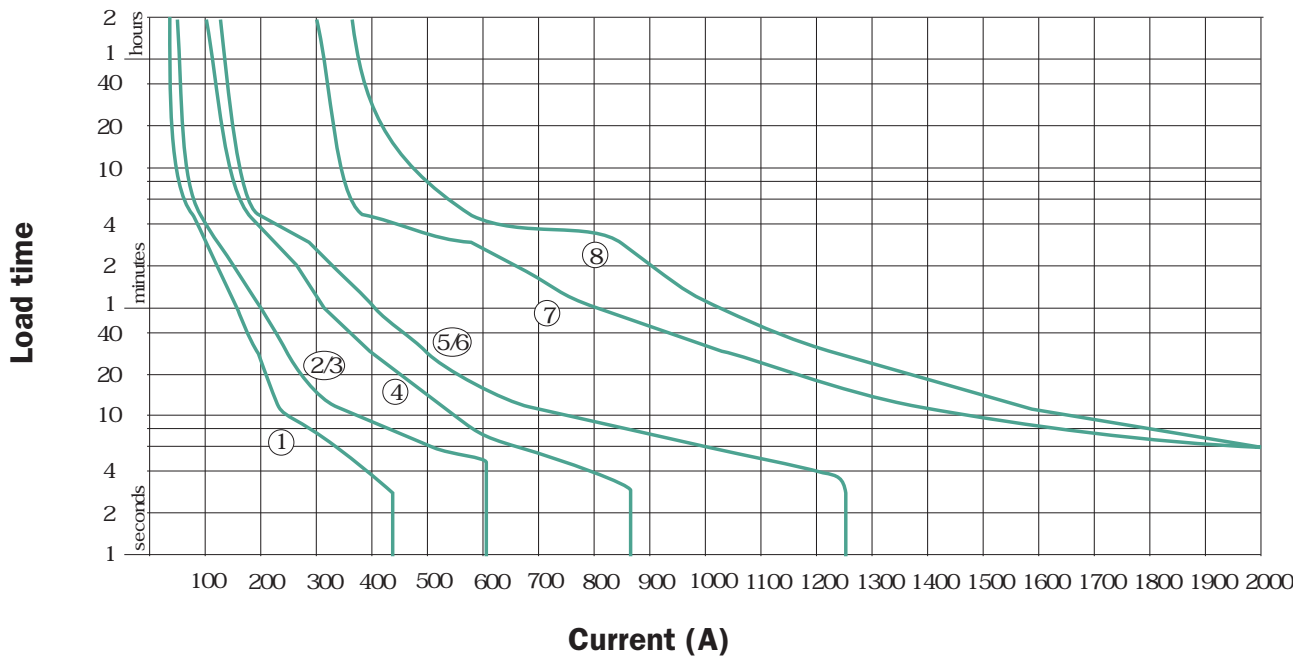

Oden AT/3X	60 V, SERIES	1
Oden AT/2X	60 V, SERIES	2
Oden AT/1X	60 V range	3
Oden AT/3X	30 V, SERIES	4
Oden AT/2X	30 V, SERIES	5
Oden AT/1X	30 V range	6
Oden AT/2X	30 V, PARALLEL	7
Oden AT/3X	30 V, PARALLEL	8

OUTPUT 0 – 30 V/60 V, Oden AT systems for 400 V 50 Hz

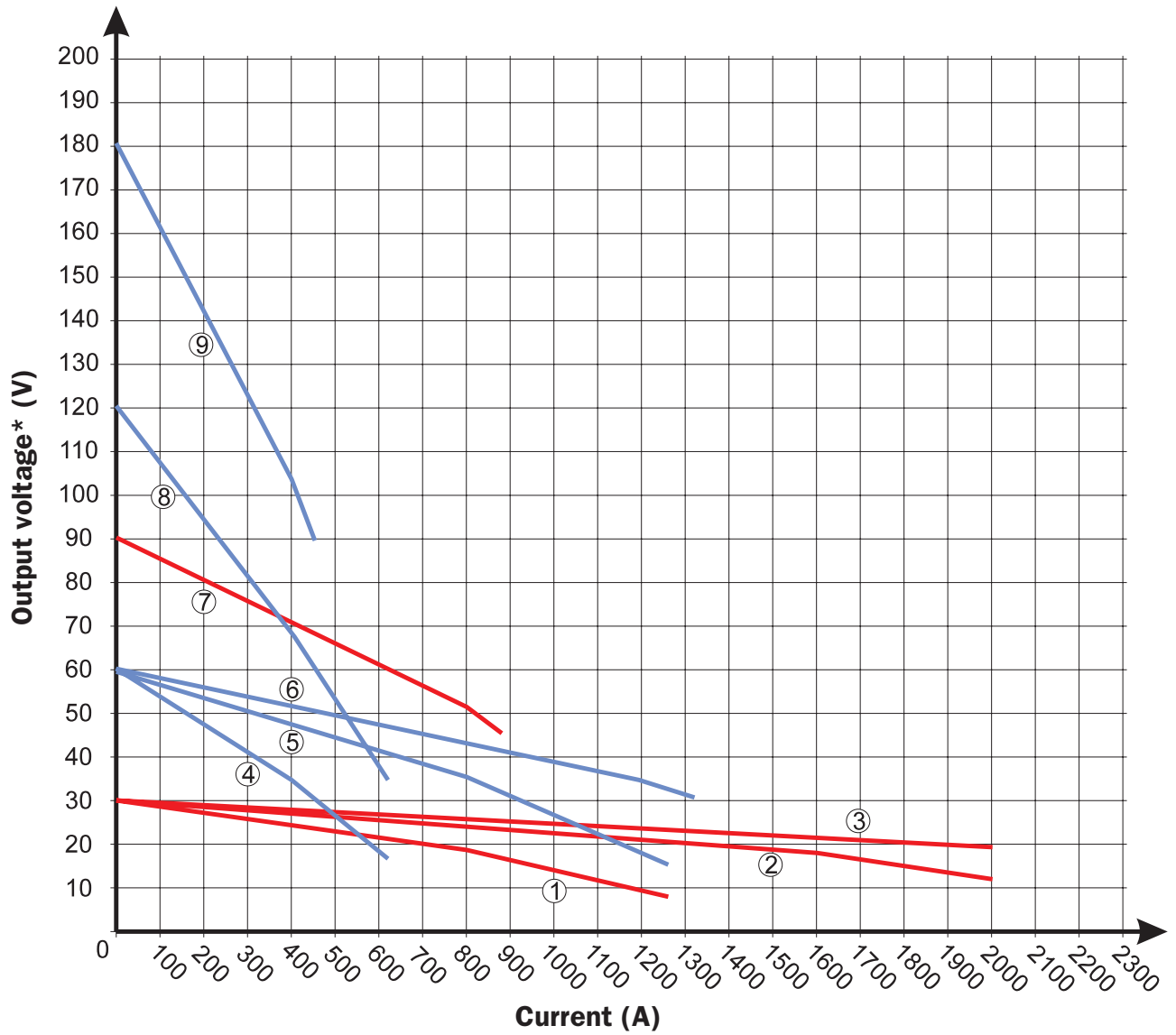

Oden AT/1X	30 V range	1
Oden AT/2X	30 V, PARALLEL	2
Oden AT/3X	30 V, PARALLEL	3
Oden AT/1X	60 V range	4
Oden AT/2X	30 V, SERIES	5
Oden AT/3X	60 V, PARALLEL	6
Oden AT/3X	30 V, SERIES	7
Oden AT/2X	60 V, SERIES	8
Oden AT/3X	60 V, SERIES	9

*) Voltage between the output terminals.

11.6 Output specifications for 480 V Oden AT systems at 60 Hz

Specifications are valid at nominal input voltage and ambient temperature +25°C, (77°F) and with the current adjustment set to 100%. The specified times refer to the maximum loading time during a single load period, they are not valid during repeated use.

Important

Exceeding the currents and load times specified could cause damage to the equipment.

The specified output voltage is the voltage at the output terminals. The voltage drop in the current cables and connections between current units in series is not included.

Nominal input voltage: 480 V AC 60 Hz

Oden AT/1S (480 V 60 Hz)

OUTPUT HIGH I

Output (A)	Voltage (V)	Time on
0	7.2	Continuous
1000	6.4	Continuous
2000	5.7	3 min
3000	4.9	1 min
4000	4.2	40 sec
5000	3.5	30 sec
6000	2.7	20 sec
7000	1.9	3 sec

Input current: Output current/66 (approximate)

Oden AT/2S (480 V 60 Hz)

OUTPUT HIGH I - Units in PARALLEL

Output (A)	Voltage (V)	Time on
0	7.2	Continuous
1000	6.8	Continuous
1900	6.4	Continuous
3000	5.9	10 min
4000	5.6	3 min
6000	4.9	30 sec
8000	4.1	10 sec
10000	3.3	6 sec
13000	2.2	3 sec

Input current: Output current/66 (approximate)

OUTPUT HIGH I - Units in SERIES

Output (A)	Voltage (V)	Time on
0	14.4	Continuous
900	12.9	Continuous
2000	11.0	3 min
3000	9.6	30 sec
4000	8.0	10 sec
6000	4.9	3 sec

Input current: Output current/33 (approximate)

Oden AT/3S (480 V 60 Hz)

OUTPUT HIGH I - Units in PARALLEL

Output (A)	Voltage (V)	Time on
0	7.2	Continuous
1000	6.8	Continuous
1900	6.6	Continuous
3000	6.3	10 min
4000	6.0	3 min
6000	5.6	30 sec
8000	5.0	10 sec
10000	4.6	6 sec
13000	3.8	3 sec

Input current: Output current/66 (approximate)

OUTPUT HIGH I - Units in SERIES

Output (A)	Voltage (V)	Time on
0	21.6	Continuous
600	20.0	Continuous
1000	19.0	30 min
2000	16.0	40 sec
3000	14.0	8 sec
4000	11.8	3 sec

Input current: Output current/22 (approximate)

Oden AT/1X (480 V 60 Hz)

OUTPUT HIGH I

See section 11.4 Oden AT/1S (480 V 60 Hz)

OUTPUT 0 – 30 V/60 V - Switch pos: 0 – 30 V

Output (A)	Voltage (V)	Time on
0	36	Continuous
160	32	Continuous
300	30	3 min
600	25	12 sec
800	22	8 sec
1200	13	2 sec

Input current: Output current/13 (approximate)

OUTPUT 0 – 30 V/60 V - Switch pos: 0 – 60 V

Output (A)	Voltage (V)	Time on
0	72	Continuous
80	65	Continuous
150	61	3 min
300	52	12 sec
400	45	8 sec
600	27	2 sec

Input current: Output current/6.7 (approximate)

OUTPUT 0 – 30 V/60 V - Switch pos: 0 – 30 V

Units in PARALLEL		
Output (A)	Voltage (V)	Time on
0	36	Continuous
380	33	Continuous
600	31	4 min
1200	28	30 sec
1600	26	10 sec
2000	24	5 sec

Input current: Output current/13 (approximate)

Oden AT/2X (480 V 60 Hz)**OUTPUT HIGH I**

See section 11.4 Oden AT/2S (480 V 60 Hz)

OUTPUT 0 – 30 V/60 V - Switch pos: 0 – 30 V

Units in PARALLEL		
Output (A)	Voltage (V)	Time on
0	36	Continuous
320	32	Continuous
600	30	2 min
1200	25	15 sec
1600	22	8 sec
2000	18	5 sec

Input current: Output current/13 (approximate)

OUTPUT 0 – 30 V/60 V - Switch pos: 0 – 30 V

Units in SERIES		
Output (A)	Voltage (V)	Time on
0	108	Continuous
120	101	Continuous
300	92	1 min 30 sec
500	83	12 sec
700	73	5 sec
800	68	3 sec

Input current: Output current/4.5 (approximate)

OUTPUT 0 – 30 V/60 V - Switch pos: 0 – 60 V

Units in PARALLEL		
Output (A)	Voltage (V)	Time on
0	72	Continuous
160	65	Continuous
300	61	3 min
600	52	12 sec
800	45	8 sec
1200	27	3 sec

Input current: Output current/6.7 (approximate)

OUTPUT 0 – 30 V/60 V - Switch pos: 0 – 60 V

Units in SERIES		
Output (A)	Voltage (V)	Time on
0	216	Continuous
60	203	Continuous
145	186	3 min
200	176	30sec
300	157	8 sec
400	138	3 sec

Input current: Output current/2.2 (approximate)

OUTPUT 0-30V/60V - Switch pos: 0-60V

Units in SERIES		
Output (A)	Voltage (V)	Time on
0	144	Continuous
80	132	Continuous
150	123	3 min
300	104	12 sec
400	92	8 sec
600	56	2 sec

Input current: Output current/3.3 (approximate)

Oden AT/1H (480 V 60 Hz)**OUTPUT HIGH I**

Output (A)	Voltage (V)	Time on
0	4.3	Continuous
1000	4.0	Continuous
1250	3.9	Continuous
2000	3.8	5 min
3000	3.6	2 min
4000	3.3	1 min 30 sec
5000	3.0	1 min
6000	2.8	40 sec
8000	2.3	20 sec
10000	1.8	12 sec
11000	1.6	5 sec

Input current: Output current/110 (approximate)

Oden AT/3X (480 V 60 Hz)**OUTPUT HIGH I**

See section 11.6 Oden AT/3S (480 V 60 Hz)

Oden AT/2H (480 V 60 Hz)**OUTPUT HIGH I - Units in PARALLEL**

Output (A)	Voltage (V)	Time on
0	4.3	Continuous
2000	4.0	Continuous
2500	3.9	Continuous
4000	3.7	5 min
6000	3.5	2 min
8000	3.3	1 min 30 sec
10000	3.0	1 min
13000	2.6	20 sec
17000	2.1	10 sec
21000	1.6	3 sec

Input current: Output current/110 (approximate)

OUTPUT HIGH I - Units in SERIES

Output (A)	Voltage (V)	Time on
0	8.7	Continuous
1250	7.9	Continuous
2000	7.6	5 min
3000	7.0	2 min
4000	6.5	1 min 30 sec
6000	5.4	30 sec
8000	4.4	10 sec
10000	3.3	5 sec

Input current: Output current/55 (approximate)

Oden AT/3H (480 V 60 Hz)**OUTPUT HIGH I - Units in PARALLEL**

Output (A)	Voltage (V)	Time on
0	4.3	Continuous
2000	4.1	Continuous
3800	3.9	Continuous
6000	3.7	5 min
8000	3.6	2 min
10000	3.4	1 min
13000	3.1	20 sec
17000	2.8	10 sec
21000	2.5	3 sec

Input current: Output current/110 (approximate)

OUTPUT HIGH I - Units in SERIES

Output (A)	Voltage (V)	Time on
0	13.0	Continuous
1250	12.0	Continuous
2000	11.3	5 min
3000	10.5	2 min
4000	9.7	30 sec
5000	8.8	10 sec
6000	8.0	8 sec
7000	7.2	5 sec

Input current: Output current/37 (approximate)

11.7 Load curves, Oden AT systems for 480 V 60 Hz

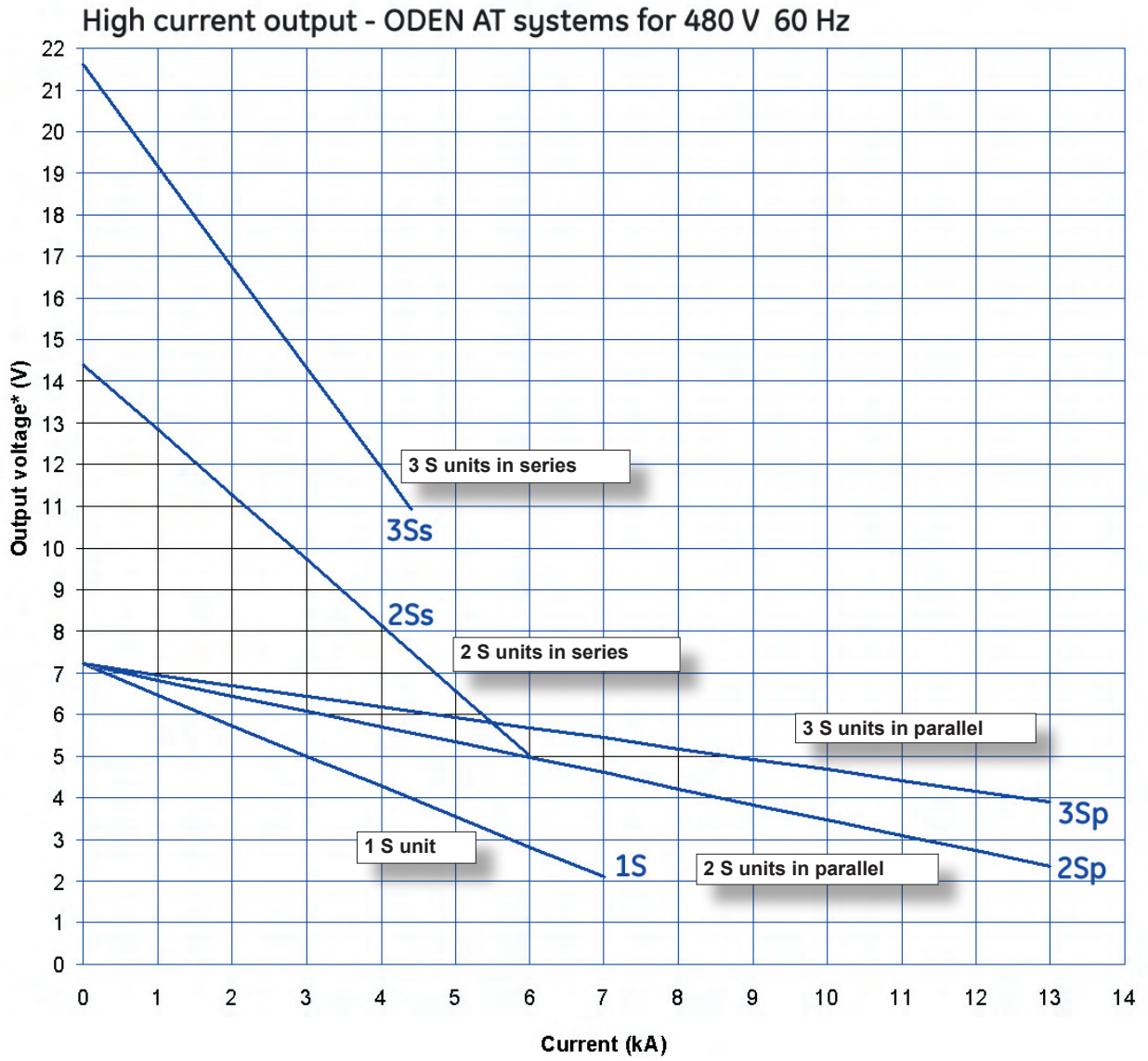

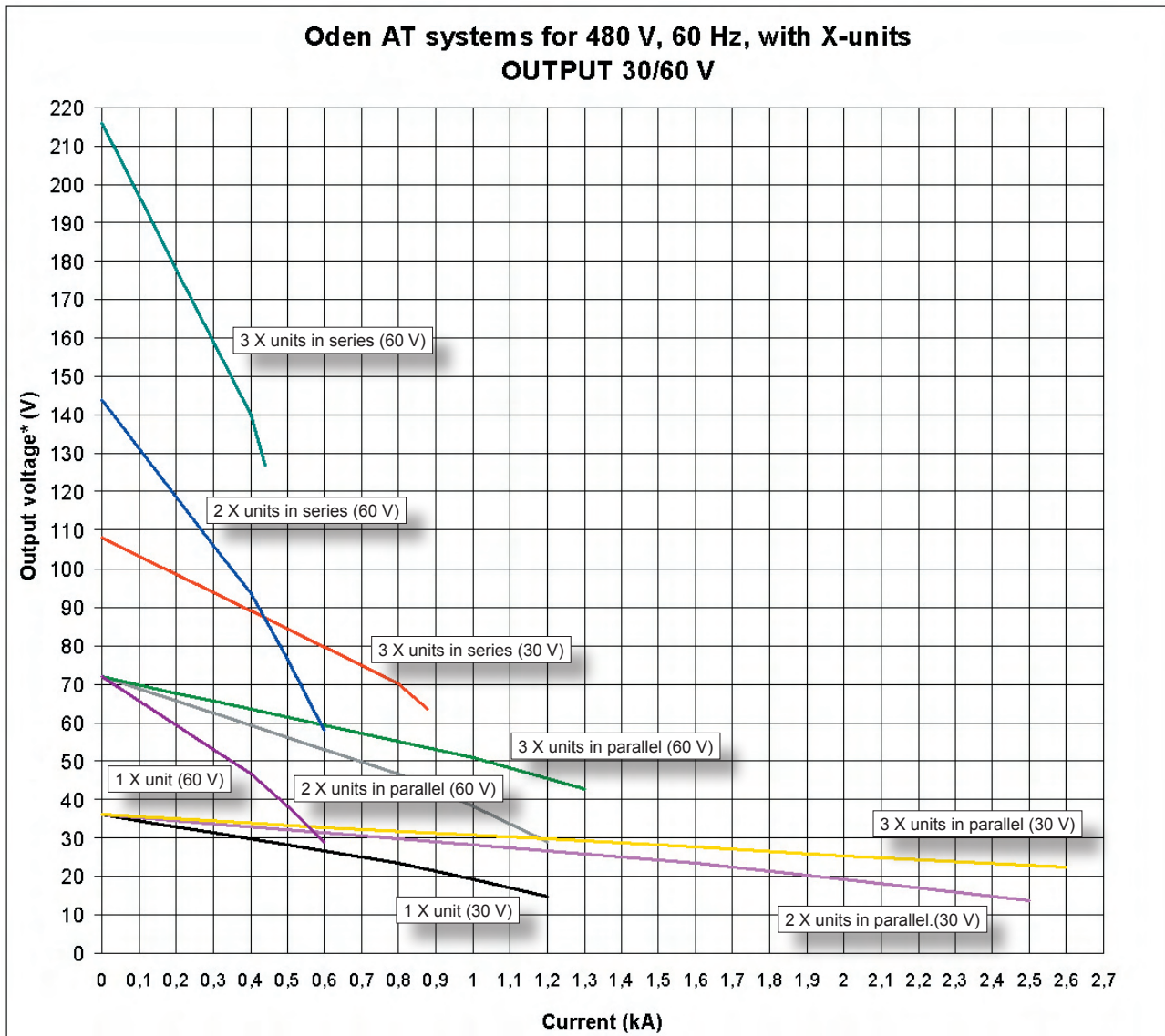

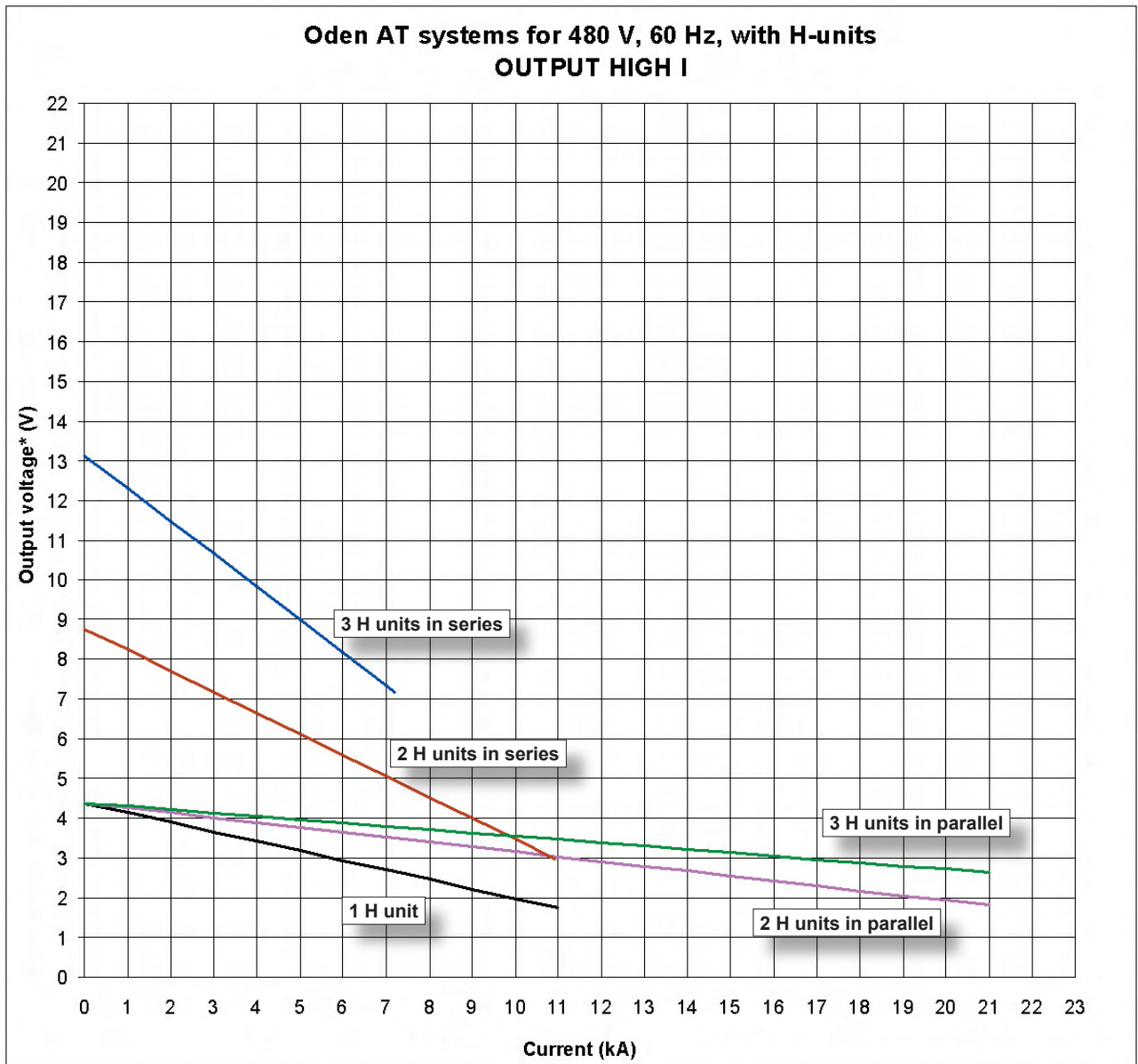

11.8 Ammeter 1

Measurement method: AC, true RMS value

Accuracy: 1% of range

Ranges: Se table below

Ammeter 1 - Ranges				
	Range LOW	Measurement resolution	Range HIGH	Measurement resolution
System with S- and X-type current units, output HIGH I				
1 current unit /units in PARALLEL	4800 A	2 A	15 kA	7 A
2 current units in SERIES	2400 A	1 A	7.5 kA	3.5
3 current units in SERIES	1600 A	0.6 A	5 kA	1.75
System with H-type current units				
1 current unit /units in PARALLEL	9600 A	4 A	30 kA	14 A
2 current units in SERIES	4800 A	2 A	15 kA	7 A
3 current units in SERIES	3200 A	1.3 A	10 kA	3.5 A
System with X-type current units, output 0-30V				
1 current unit /units in PARALLEL	960 A	0.4 A	3 kA	1.4 A
2 current units in SERIES	480 A	0.2 A	1.5 kA	0.7 A
3 current units in SERIES	320 A	0.13 A	1 kA	0.35 A
System with X-type current units, output 0-60V				
1 current unit /units in PARALLEL	480 A	0.2 A	1.5 kA	0.7 A
2 current units in SERIES	240 A	0.1 A	750 A	0.35 A
3 current units in SERIES	160 A	0.06 A	500 A	0.175 A

11.9 Stop input

This input is equipped with a 400 V voltage suppressor between the terminals.

STOP INPUT				
Parameter	Min	Type	Max	Unit
Potential state				
High changeover level, DC	20			V DC
Low changeover level, DC			5	V DC
High voltage level, AC 1)	60			V AC rms
Low voltage level, AC 1)			3	V AC rms
Input current at high level, AC / DC	1		5	mA
Contact state				
Changeover resistance	6			k Ω
Low changeover resistance			1	k Ω
Output current with short circuited input	5		13	mA DC
Internal supply voltage, Vs		20		V DC
Maximum values				
Input voltage, DC			275	V DC
Input voltage, AC			250	V AC rms
1) This level is needed to provide correct time readings.				

Appendix 1

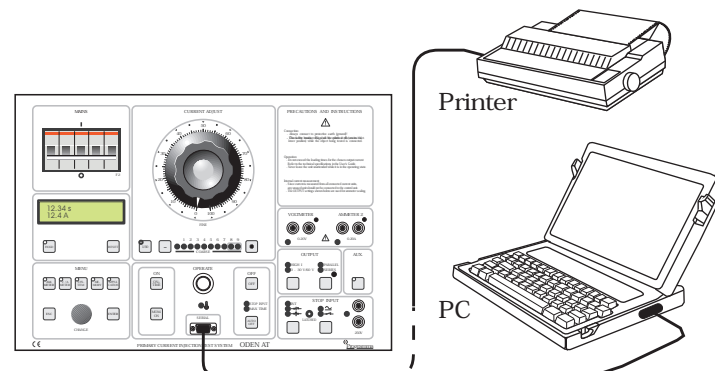

A1.1 Transferring test data to a PC or a printer

Test data from Oden AT can be transferred to a PC for further processing or to a printer (like the serial printer Epson FX85) for immediate print-out.

The transfer to a PC is made between the serial port on Oden AT and the serial port on the PC, using a straight pin-to-pin cable and a communications program, such as the terminal program featured in Windows (or something similar to this). The transfer of test data is initiated each time the <ENTER> key is pressed.

A1.2 Setting up the connection

1. Connect the serial port on Oden AT to the serial port on the PC using a straight pin-to-pin cable.

Important!

After the tests is completed you must click the "Stop" button in the terminal program, otherwise you might risk losing parts of the test data.

How to connect via Win 9X Hyper Terminal

Start Hyper Terminal in the Accessories menu.

Note If Hyper Terminal is not installed you will have to install it in the "Install/uninstall softwares" in the Control panel.

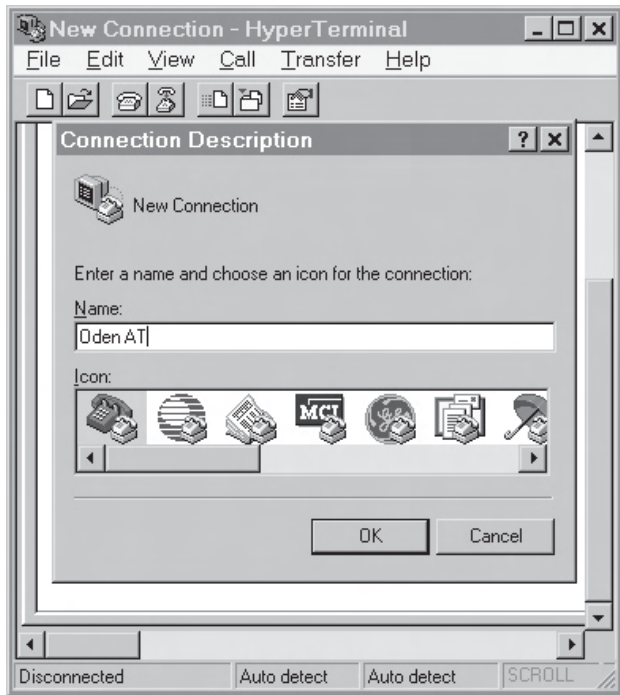

1. Type a name of the connection, choose an icon and click *OK*.



2. Select "Direct to COM1" or "Direct to COM2" and click *OK*.

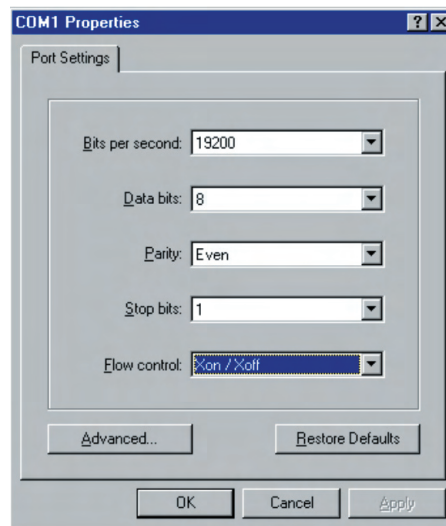

3. Select:

Bits per second	19200
Data bits	8
Parity	Even
Stop bit	1
Flow control	Xon/Xoff

4. Click "OK".
5. Click on "Transfer" and select "Capture Text".

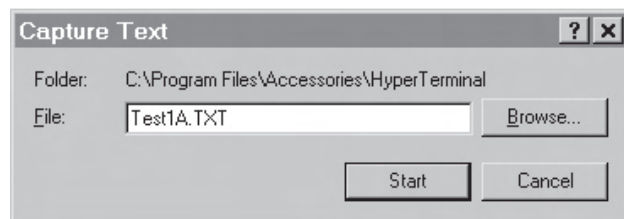

6. Enter the name of the file where the data should be stored and click on "Start".
7. When the test is finished click on "Transfer" select "Capture Text" and click on "Stop".

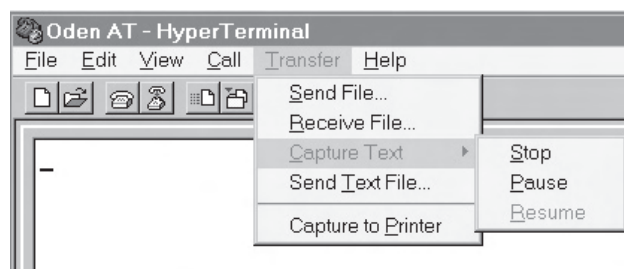

Note If you get problems with data transferring, check the Properties for the Port Settings. First select "File" and "Exit". Then restart by clicking the icon you have chosen for the connection. Select "File", "Properties" from the menu bar. Then click on "Configure" to go to the "Port Settings".

How to connect via Win 2000 Hyper Terminal

1. Start Hyper Terminal. You will find it under Start, Programs, Accessories, Communications

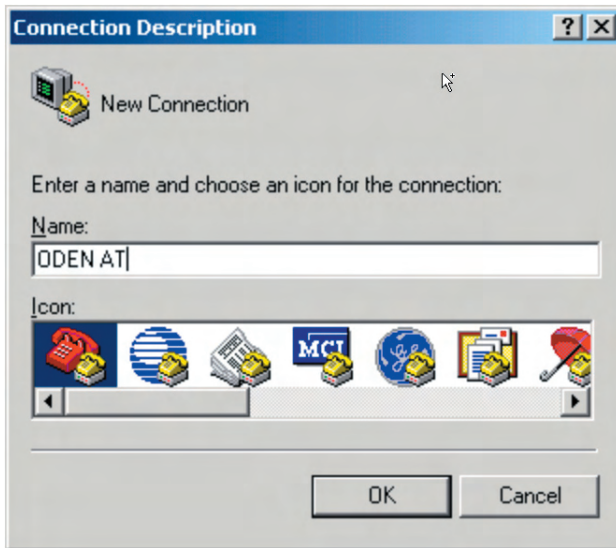

2. Type the name of the connection and click OK



3. Select COM1 (Hyper terminal Windows 2000) and click OK

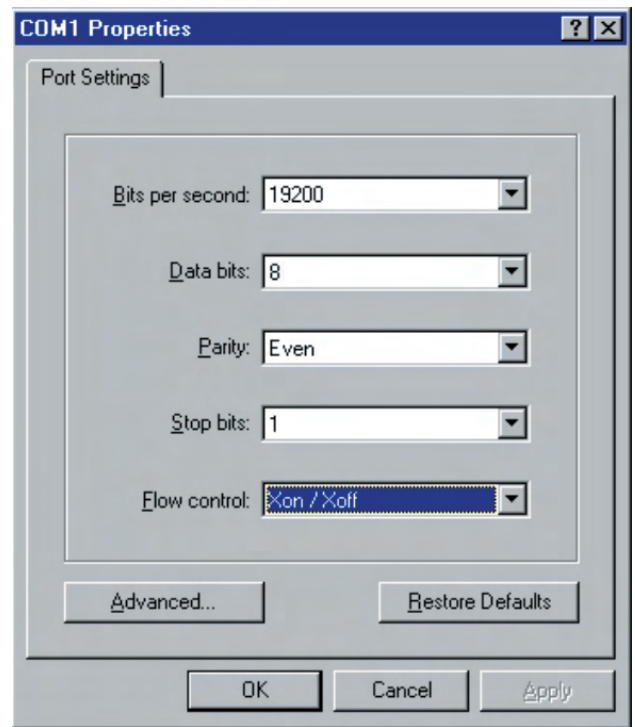

4. Select:

Bits per second:	19200
Data bits:	8
Parity:	Space
Stop bits:	1
Flow control:	None

5. Click "OK".
6. Click on "Transfer" and select "Capture Text"

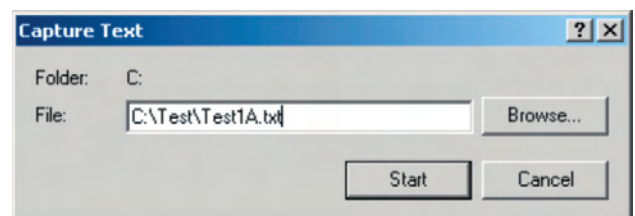

7. Enter the name of the file where the data should be stored and click on "Start"
8. When the test is finished, click on "Transfer" and select "Capture Text" and click on "Stop"

Note If you need to check or change the settings, start by clicking on the icon for the connection, click the button "disconnect", the button "properties" and then on "Configure".

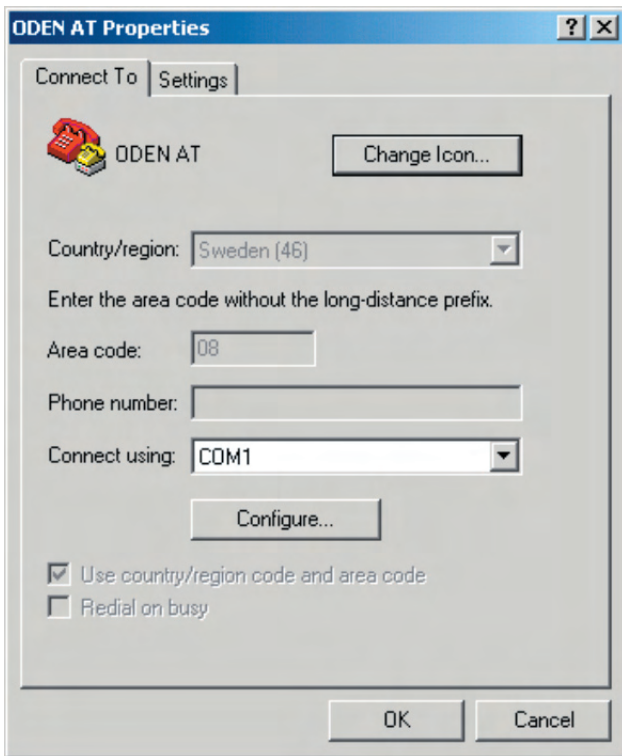

A1.3 Transfers in "NORMAL USE"

Data measured by Oden AT will be dumped to the PC (or printer) each time you press <ENTER>. The downloaded data contains this:

- Current measured by Ammeter 1 (amperes)
- Time (seconds)
- Current measured by Ammeter 2 (amperes)
- Voltage (volts)
- Phase angle (degrees)
- I_{max} (amperes)

Example of transfered data:

288;A; 6.538;s; 0.290;A;-;V; 182;Deg; 290;A; I_{max}
 908;A; 1.697;s; 0.917;A;-;V; 182;Deg; 910;A; I_{max}
 951;A; 3.339;s; -;A;0.099;V; 2;Deg; 960;A; I_{max}

A1.4 Transfers in applications "TEST RECLOSER" and "SECTIONALIZER"

Measured data from a test in the "TEST RECLOSER" and "SECTIONALIZER" applications will be dumped to the PC (or printer) each time you press <ENTER>. The downloaded data contains this:

- Number of operations
- Total accumulated time (seconds)
- Trip times and current (seconds, amperes)
- Reclosing times and current (seconds, amperes)

Example of transferred data:

```
2;OP
TAT; 0.673;s
T01;0.397;s; 47;A
R01;0.254;s; 0;A
T02;0.419;s; 47;A
R02;0.000;s; 0;A
T03;0.000;s; 0;A
R03;0.000;s; 0;A
T04;0.000;s; 0;A
R04;0.000;s; 0;A
T05;0.000;s; 0;A
R05;0.000;s; 0;A
```

Appendix 2

A2.1 Resistance measurement accuracy

Factors that influence accuracy

- Flux inducing voltage in the sense cables
- High phase shift between voltage and current
- Material in the test circuit that saturates or have losses
- Distortion in mains voltage
- Accuracy of the current and voltage measurement

Twist the sensing cables in order to eliminate openings where flux can pass and induce voltage. Preferably also twist the current cables in order to reduce flux from them.

Choose a current that both current and voltage values are at more than 50 % of full measurement range.

Accuracy estimation

Accuracy can be estimated to the sum of the accuracy for the voltmeter and the ammeter provided that the following conditions apply.

- current and voltage values are at > 50 % of full range.
- voltage induction due to flux and distortion is negligible.
- phase shift between voltage and current is less than 30 degrees.
- there is no material close to the circuit that saturates or has iron losses.

Accuracy for voltage and current measurements:
+/- 1 digit +/- 1 % of measurement range.

Voltmeter ranges: 0 - 0.200 V, 0 - 2.000 V,
0 - 20.00 V, and 0 - 200.0 V.

Ammeter range depends on the configuration used and whether current units are connected in series. See chapter 11 Specifications, section 6.

Index

Symbols

0-30/60 V 18

A

Active power (P) 45
 alarm 19
 AMMETER 20
 Ammeter 1 98
 APPLICATION 20
 arrange the cable sets 36
 AUTO OFF 25

C

Cables
 twist 28
 voltage drop 40
 cable sets 36
 Carriage 27
 Circuit breaker 62
 Circuit breaker resistance 62
 conductors 33
 configuration 49
 Connect Oden AT 28
 Contact mode 18
 Control panel
 AUX block 18
 CURRENT ADJUST block
 FINE knob 18
 MAINS block 17
 MENU block 20
 OPERATE block 19
 OUTPUT block 18
 VOLTMETER AND A-METER 2 block 18
 control panel 17
 Cos j 45
 CT 24, 60
 Current
 adjustment coarse 39
 adjustment fine 39
 cables
 twist 39
 voltage drop 39
 continuous generation 41
 generate 39
 maximum possible 42
 reference, phase angle 44
 Current adjustment
 resolution 42
 Current cables
 twist 28, 42
 current cables 49
 Current transformer 60
 Current units 28

D

Directional indicators 21
 Display 21
 Drop-out 46

E

Earthing
 Oden AT 31

F

Freezing measured values 43

G

Generate a pulse-train 43
 Generate current 39
 Generating
 briefly 40
 continuously 41
 limited time 40, 41, 47
 Grounding
 Oden AT 31
 Ground grid integrity testing 65

H

Heating of objects 40
 HIGH I 18
 HOLD 20
 Holding measured values 43

I

I/30 function 40
 Impedance
 test object 29, 40, 42
 Impedance (Z) 45
 Injecting
 briefly 40
 continuously 41
 limited time 40, 41, 47
 momentary 46
 Instantaneous pick-up 48
 Instantaneous trip time 48
 Instantaneous trip unit measurement 60
 INT 18
 Internal detection INT 18

L

Low-voltage circuit breaker 59
 measuring
 instantaneous trip 60
 tripping limit 59
 tripping time 59

M

MAINS block	17
Mains power	32
Mains voltage	32
MAX TIME	41, 47
MAX TIME function	41
MAX TIME lamp	41
Measure operating time	40
Measuring	
impedance (Z)	45
micro-ohm value	62
operating limits	46
power (P)	45
power factor (cos j)	45
reactive power (Q)	45
resistance (R)	45, 62
Measuring the resistances of breakers	62
MEMORY	20, 25
Micro-ohm measurement	62
induced currents	62
running cables	62
sensing cables	62
Microhmmeter testing	62
Momentary injection	46
MOM ON	40, 46

O

O.F.	21
OFF state	23
Operating limits	46
Operating time	40
Overflow	21

P

P	45
PARALLEL	18
Parallel connection	30
Phase angle	44
Pick-up test	46
Polarity of a current transformer	61
Power (P)	45
Power factor	45
Power factor (cos j)	45
power supply	32
Precaution levels	9
Protective relay	46
Pulse trains	43

Q

Q	45
---	----

R

R	45
Ratio of a current transformer	24, 60
Reactance (X)	45
Reactive power (Q)	45
Recloser	63

number of operations	63
reclosing times	63
RS-232 data	105
time test	63
total accumulated time	63
trip times	63
Reclosing times	63
RESET	20
Resistance (R)	45
Resistance measurement accuracy	107
RS-232	101

S

S	45
Safety precautions	9
Sectionalizer	64
no. of pulses until lockout	64
presetting current pulses	64
RS-232 data	105
selecting ODEN AT system	50
SERIAL port	101
SERIES	18
Series connection	29
SYSTEM	20

T

Temperature alarm	19
Testing	
pick-up	46
polarity of current transformer	61
protective relay	46
sectionalizer	64
Testing a sectionalizer	64
The display	21
Time test	
circuit breaker	59
recloser	63
relay	47
Total accumulated time	
recloser	63
Transferring test data	101
Transferring test data to a PC	101, 107
Transportation	27
Trip times	
recloser	63
Turns ratio of a current transformer	24
Twisted-pair cables	28

V

V/A METER	20
Virtual power (S)	45
Voltage drop	28, 40
current cables	40
Voltage mode	18

W

Win-95 Hyper Terminal	102
Win 2000 Hyper Terminal	103

X

X45

Z

Z45

