

MAH 503

Multi-Contact

MC

STÄUBLI GROUP

Typ / Type **XL-410**

Best.-Nr. / Order No.
No de cde **66.9196-***



* Farbcode gemäss Katalog / Colour code see catalogue / Code couleur voir catalogue



PEWA
Messtechnik GmbH
Weidenweg 21
58239 Schwerte
Tel.: 02304-96109-0
Fax: 02304-96109-88
E-Mail: info@pewa.de
Homepage: www.pewa.de

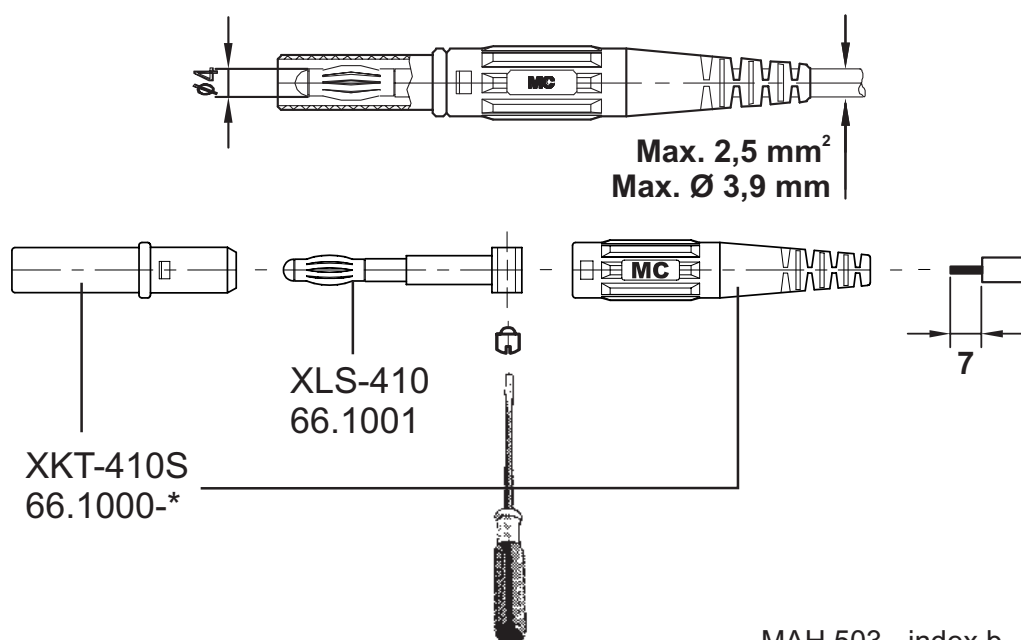

MAH 503 - index b