



**PEWA**  
Messtechnik GmbH

Weidenweg 21  
58239 Schwerte

Tel.: 02304-96109-0  
Fax: 02304-96109-88  
E-Mail: [info@pewa.de](mailto:info@pewa.de)  
Homepage : [www.pewa.de](http://www.pewa.de)



## HI 504910

---

### Digital Transmitter

Instruction Manual

## TABLE OF CONTENTS

---

WARRANTY . . . . .	4
PRELIMINARY EXAMINATION . . . . .	5
GENERAL DESCRIPTION . . . . .	5
FUNCTIONAL DESCRIPTION . . . . .	6
SPECIFICATIONS . . . . .	9
INSTALLATION . . . . .	10
CALIBRATION MODE . . . . .	12
SETUP MODE . . . . .	22
MEASURE MODE . . . . .	28
ERRORS . . . . .	28
pH/ORP PROBE CHECK . . . . .	30
TEMPERATURE COMPENSATION . . . . .	31
LAST CALIBRATION DATA . . . . .	32
OFFSET AND SLOPE DIRECT SELECTION . . . . .	34
EVENT LOG FILE SCROLLING . . . . .	36
FAULT CONDITIONS . . . . .	38
RS485 COMMUNICATION . . . . .	39
MODEM CONNECTION . . . . .	50
SELFTEST PROCEDURES . . . . .	53
pH VALUES AT VARIOUS TEMPERATURES . . . . .	56
ELECTRODE CONDITIONING AND MAINTENANCE . . . . .	57
ACCESSORIES . . . . .	60
CE DECLARATION OF CONFORMITY . . . . .	65
USER NOTES . . . . .	66

Dear Customer,

Thank you for choosing a Hanna Product.

Please read this instruction manual carefully before using the instrument. It will provide you with the necessary information for correct use of the instrument, as well as a precise idea of its versatility.

If you need additional technical information, do not hesitate to **e-mail us at [tech@hannainst.com](mailto:tech@hannainst.com)**.

This instrument is in compliance with the **CE** directives.

## WARRANTY

The **HI 504910 meter is warranted for two years (sensors, electrodes and probes for six months)** against defects in workmanship and materials when used for their intended purpose and maintained according to instructions. This warranty is limited to repair or replacement free of charge.

Damage due to accidents, misuse, tampering or lack of prescribed maintenance are not covered.

If service is required, contact the dealer from whom you purchased the instrument. If under warranty, report the model number, date of purchase, serial number and the nature of the failure. If the repair is not covered by the warranty, you will be notified of the charges incurred. If the instrument is to be returned to Hanna Instruments, first obtain a Returned Goods Authorization number from the Customer Service department and then send it with shipping costs prepaid. When shipping any instrument, make sure it is properly packaged for complete protection.

© 2003 Hanna Instruments

All rights are reserved. Reproduction in whole or in part is prohibited without the written consent of the copyright owner.

Hanna Instruments reserves the right to modify the design, construction and appearance of its products without advance notice.

## PRELIMINARY EXAMINATION

Remove the instrument from the packing material and examine it carefully to make sure that no damage has occurred during shipping. If there is any noticeable damage, notify your Dealer or the nearest Hanna Customer Service Center immediately.

**Note** Save all packing materials until you are sure that the instrument functions correctly. Any damaged or defective items must be returned in their original packing materials together with the supplied accessories.

## GENERAL DESCRIPTION

**HI 504910** acquires and transmits in a digital format towards **HI 504** controller, or a computer workstation, pH, ORP and °C measurements.

The digital link allows to send additional information, especially regarding the pH, ORP and temperature probes.

## MAIN FEATURES

- pH/ORP probe check.
- Pt100 or Pt1000 sensor with automatic recognition and damage test.
- Setup procedure to configure general and measurement related parameters. There are two separate sets of configuration parameters, one for pH and one for ORP, thus no loss of setting occurs when changing from pH to ORP and vice versa.
- Calibration: usual pH calibration at 2 points, or quick single point pH calibration through **HI 504920** reference pH meter.
- Old probe check, dead probe check, last calibration data internally recorded: calibration date and time, pH offset, pH slope, number of calibration points and correspondent pH values.
- Manual temperature compensation available (automatically selected when a temperature input error occurs).
- Possibility of a remote connection to a computer workstation through an external modem/GSM module.
- Data logging: 6000 samples pH/°C or ORP downloadable through RS485 and **HI 92500** application software.

# FUNCTIONAL DESCRIPTION

Front view

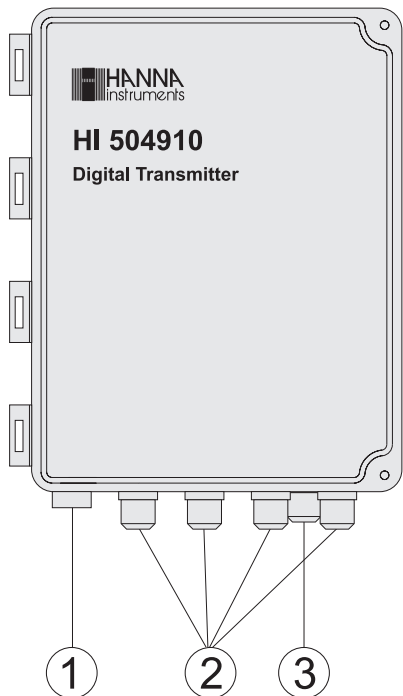

Inside view

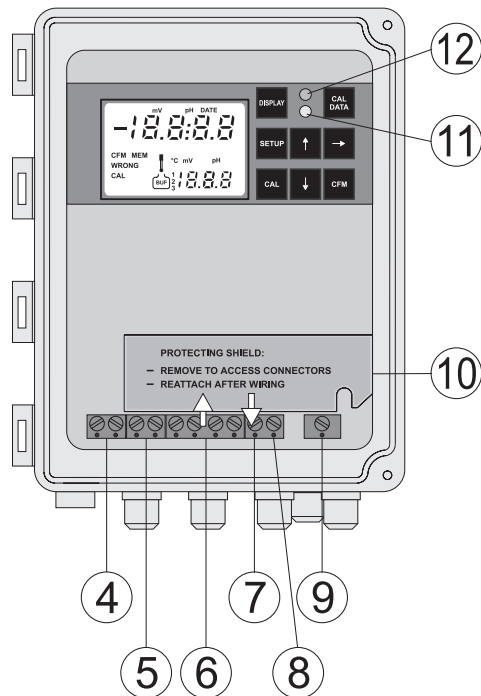

Keyboard and LCD for HI 504910 are normally provided by HI 504920. To do this, HI 504920 has to be put into terminal mode, by selecting code 90 in Setup mode.

If the HI 504920 meter is not handy, the keyboard and LCD inside the transmitter case can be used for configuring, calibrating and monitoring HI 504910.

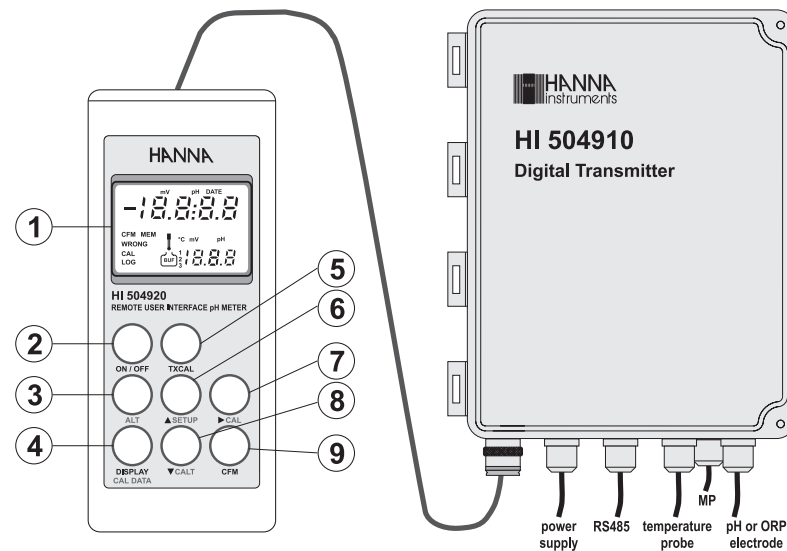

1. Infrared optical interface for HI504920
2. Cable glands for 24 VDC power supply, for HI504 or computer workstation connection, for pH (or ORP) electrode & temperature probe inputs
3. Cable gland for Matching Pin connection
4. Power supply input (24V AC/DC)
5. RS485 connections to HI504, PC, modem, GSM module
6. Connections for Pt100/Pt1000 temperature sensor
7. Connection for Potential Matching Pin
8. Connection for electrode reference
9. Connection for pH or ORP electrode input
10. Protecting shield: remove to access connectors; reattach after wiring.
11. Green status LED
12. Red status LED

1. Liquid Crystal Display
2. ON/OFF key, to turn the HI 504920 on and off.
3. ALT key, to activate alternate key functions
4. DISPLAY / CAL DATA key, to enter/exit the event scrolling mode, to view pH buffer or °C while calibrating pH, and to view last calibration data (with ALT)
5. TXCAL key, for quick single point pH calibration
6. □ SETUP key, to move up or enter/exit the Setup mode (with ALT)
7. □ CAL key, to move right or enter/exit the calibration mode (with ALT)
8. □ CALT key, to move down (no alternate function for HI 504910) to confirm values.
9. CFM key, The device can be restarted at any time by pressing CFM, ALT and □ SETUP together (CFM first)

**Note** Throughout this manual every reference to keyboard or LCD refers to **HI 504920** keyboard and LCD.

When using the **HI 504910** internal keyboard and LCD, refer to the below table to match keys.

HI 504920	HI 504910
DISPLAY	DISPLAY
(ALT+) CAL DATA	CAL DATA
(ALT+) SETUP	SETUP
□	□
□	□
(ALT+) CAL	CAL
□	□
CFM	CFM

The two LCD's have the same appearance; the only difference is the LOG tag blinking on the **HI 504920** display to indicate that the meter is operating in terminal mode.

## SPECIFICATIONS

Range	-2.00 to 16.00 pH -2000 to 2000 mV -30 to 130.0 °C
Resolution	0.01 pH 1 mV 0.1 °C
Accuracy (@20°C/68°F)	±0.02 pH ±2 mV ±0.5 °C
Typical EMC Deviation	±0.2 pH ±10 mV ±0.5 °C
Temperature compensation	Automatic or manual from -30 to 130 °C
Temperature probe	With 3-wire or 2-wire Pt100/Pt1000 sensor (with automatic recognition and damage test)
Installation Category	<b>II</b>
Power Supply	24V AC/DC ± 20%
Power Consumption	5 VA
Over Current Protection	400 mA 250V FAST FUSE
Infrared optical interface towards HI 504920	RS232, baud rate fixed to 2400
Data logging	6000 pH/°C or ORP samples
Environment	0 to 50 °C; max 85% RH non-condensing
Enclosure	Fiberglass NEMA case 4X type
Dimensions	216 x 165 x 108 mm (8.5 x 6.5 x 4.25") excluding mounting feet
Weight	1.5 kg (3.3 lb.)

# INSTALLATION

- Remove the connectors protecting shield and wire the meter as explained below.

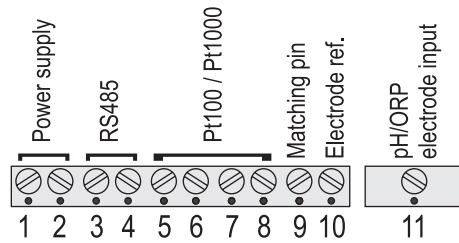

- Power supply input (24V AC/DC):** connect a 2-wire power cable (with a minimum cross area of 0.75 mmq) to the terminals #1 and #2.  
If using a DC supply, connect the positive wire to the terminal #1.
- RS485 serial interface** (for communicating with HI 504 controller or PC/modem/GSM module): connect a twisted shielded cable to terminals #3 (B) and #4 (A).

**Note** The serial interface of the HI 504910 Digital Transmitter is optoisolated. Do not connect the serial cable shield to the transmitter.

- Pt100/Pt1000 terminals:** use these contacts to connect the Pt100/Pt1000 temperature sensor for automatic temperature compensation of pH measurement.

In the case of shielded wire, connect the shield to pin #5.

In the case of a 2-wire sensor connect the Pt100/Pt1000 to pins #7 and #8, and short pins #6 and #7 with a jumper wire.

If the Pt100/Pt1000 has more than 2 wires, connect the two wires of one end to pins #6 and #7 (pin #6 is an auxiliary input to compensate for the cable resistance) and one wire from the other end to pin #8. Leave the fourth wire unconnected, if present.

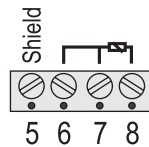

**Note** The instrument automatically recognizes the sensor type (Pt100 or Pt1000).

- pH or ORP electrode:** connect the shield of the electrode coaxial cable (electrode reference) to the terminal #10, and the electrode coaxial cable core to terminal #11.

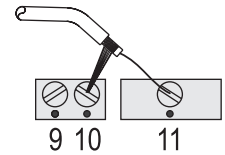

To benefit from the differential (symmetrical) input, connect the proper electrode wire or a cable with a potential matching pin (grounding bar) to the relevant terminal (#9).

If the matching pin is not available, short pins #9 and #10.

**Note** All connected cables should end with cable lugs.

**Note** After wiring, always reattach the protecting shield.

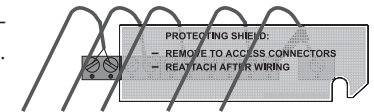

## DIMENSIONS

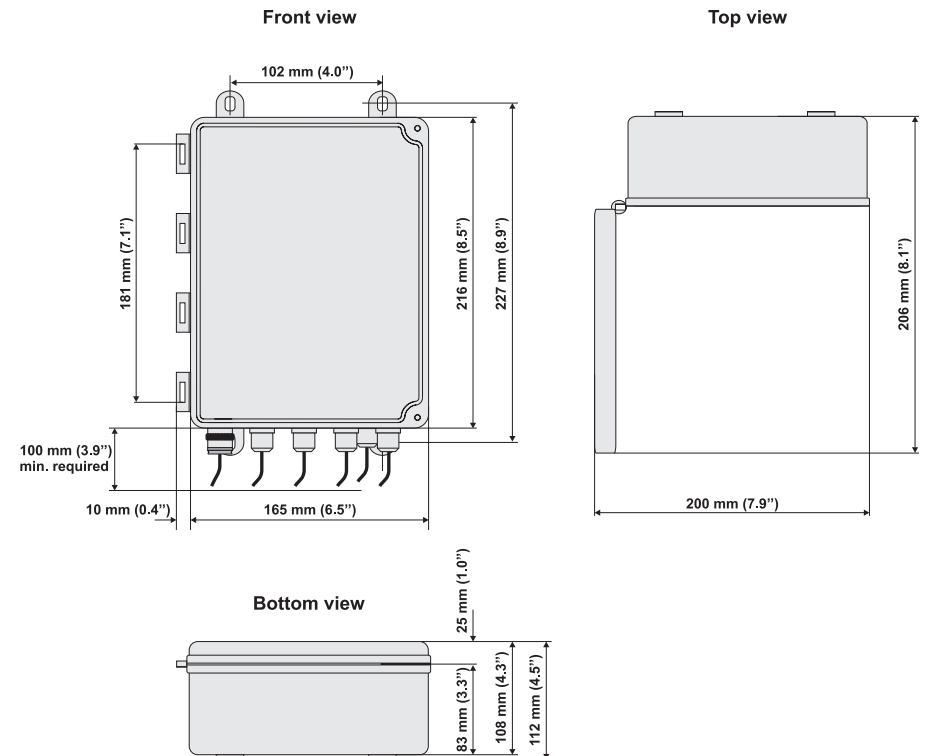

## CALIBRATION MODE

The calibration mode allows to calibrate the pH/ORP and temperature inputs.

The instrument is factory calibrated for all these parameters. Periodical calibration of the instrument is recommended, in particular when greatest accuracy is required and at least bi-yearly.

The electrode can be calibrated over only one point but, when possible, it is always good practice to perform a 2-point calibration.

### QUICK SINGLE-POINT pH CALIBRATION (through HI 504920)

A quick single point pH calibration at the pH value of the solution monitored by HI 504910 transmitter can be performed. HI 504920 serves as a reference pH meter.

Unlike the usual calibration with buffers, this quick procedure is carried out without having to interrupt normal measurement.

**Note** For better accuracy, from time to time it is recommended to perform a 2-point calibration procedure, which allows to adjust not only the offset but also the slope of the pH probe.

- Connect the HI 504920 meter to HI 504910 through the infrared interface cable.
- Immerse the pH electrode of the HI 504920 meter into the solution measured by HI 504910, as close as possible to the pH probe of HI 504910. Wait a few seconds for stabilization.
- When the HI 504920 meter displays the pH measurement, press TXCAL (HI 504920 must be out of the HI 504910 terminal mode).
- The LCD will display "CALt" for a couple of seconds to indicate that the calibration of the HI 504910 transmitter is in progress.
- If the calibration is completed correctly, the LCD will flash the "Good" message for a few seconds. (Also the red LED flashes once).

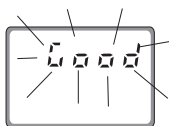
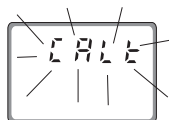

**Note** If the probe offset is outside the allowed limits, if the HI 504910 transmitter is configured for ORP measurement, or if some other error occurs during calibration, the display will flash a "bAd" message. Press TXCAL to return to normal mode and restart the calibration procedure from the beginning.

- The primary LCD will then display the pH reading of the HI 504910 transmitter, while the secondary LCD will show the HI 504920 reading. Both pH tags blink alternatively.



**Note** The two values may differ a little if the measured solution is not stable. For an accurate calibration, perform the single point procedure only when readings are stable.

- To exit the calibration mode, press TXCAL.

**Note** It is advisable to perform the entire calibration procedure keeping the HI 504920 meter and the HI 504910 transmitter connected through the infrared optical interface.

- It can happen that HI 504910 is positioned in a difficult-to-reach place while the pH probe of HI 504920 is immersed in the solution: the two instruments will be not connected, and when the primary LCD shows the blinking "CALt" message, the secondary display will show a countdown starting from 120 seconds. In this situation, the pH probe can be taken out of the solution, while the interface cable has to be connected to the HI 504910 transmitter before the countdown reaches zero. Calibration then continues, and at the end of the procedure the pH tag of the secondary LCD will not blink.

**Note** If the infrared cable is not connected before the end of the countdown, the LCD shows the "tiMEout" message and the calibration is not completed.

**Note** It is possible to check the HI 504910 pH reading against the HI 504920 pH reading at any time, without calibrating the HI 504910 transmitter.

- Press (ALT+) TXCAL.
- The primary display will show the HI 504910 pH reading, while the secondary LCD displays the

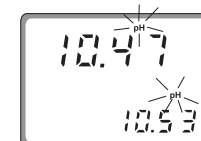

**HI 504920** pH reading. Both pH tags blink alternatively.

- To return to normal mode, press ALT and TXCAL.
- If a communication error between the portable meter and the transmitter occurs, the primary LCD shows the "rSEr" message: check the interface cable and connections.
- If the LCD shows "...", verify that the **HI 504910** transmitter be configured for pH (not for ORP) measurement.

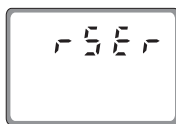

**Note** Whenever a pH or ORP calibration is performed by means of **HI 504920**, the **HI 504920** date and time are automatically set in **HI 504910**.

### USING HI 504920 AS TERMINAL FOR HI 504910

Select code 90 in Setup mode and press CFM to confirm. The **HI 504920** enters the Terminal mode and the LOG tag blinks on the LCD.

**Note** In this situation it is not necessary to connect the electrode to the **HI 504920** portable meter, which is working as keyboard and LCD for the **HI 504910** transmitter.

To enter the calibration mode press (ALT+) CAL.



Enter the correct password and press the CFM key. If a wrong password is entered, the instrument returns to the previous mode.

**Note** If the meter is set to measure ORP (setup item G.00), the pH calibration, pH reading offset adjustment, and pH offset and slope are not available. If the meter is configured for pH, no ORP calibration can be selected.

**Note** Any calibration procedure can be aborted at any time by pressing (ALT+) CAL, and the instrument returns to the previous mode.

### pH CALIBRATION

To perform any pH calibration procedure, the instrument has to be set as pH meter. The meter can be calibrated through a one-point or two-point calibration.

### Initial Preparation

The pH calibration can not be performed if the pH electrode is broken or leaking or the reference electrode is broken or dirty and an error is active. The ORP calibration can not be performed if the "Reference electrode broken or dirty" error is active. The temperature probe should be connected to the instrument.

Pour small quantities of pH 7.01 (**HI 7007**) and pH 4.01 (**HI 7004**) or pH 10.01 (**HI 7010**) solutions into individual beakers. If possible, use plastic beakers to minimize any EMC interference.

For accurate calibration use different beakers for each buffer solution, the first one for rinsing the electrode and the second one for calibration. By doing this, contamination between buffers is minimized.

- Enter the calibration mode, select the pH calibration (by moving through the menu with the  $\square$  and  $\square$  keys), then press the CFM key.
- Choose the pH buffer set between the two available ones: the standard set (4.01, 7.01, 10.01) and the NIST set (4.01, 6.86, 9.18). For the standard set confirm the "Std"; for the NIST set confirm the "niSt" (use the  $\square$  and  $\square$  keys for select between the two options).

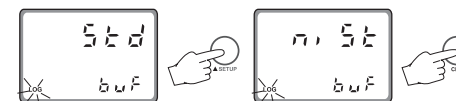

The default buffer set is the one used for last calibration, even if the procedure was not completed.

- Once confirmed the set of buffer values, the primary LCD shows the measured pH value, while the secondary LCD displays the first required buffer value.

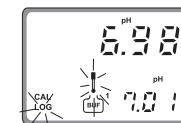

### Two-point calibration

- Remove the protective cap from the pH electrode and immerse it into the buffer solution (e.g. pH 7.01) together with the Potential Matching Pin and the temperature probe, then stir gently.



**Note** The electrode should be submerged approximately 4 cm (1½") in the solution. The temperature probe has to be located as close as possible to the pH electrode.

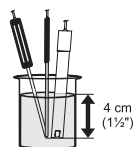

**Note** When it is not possible to immerse the Potential Matching Pin together with the pH electrode in the solution, disable the differential input by setting setup item I.04 to "OFF".

- When the reading becomes stable, the probe indicator will stop flashing (after about 30 seconds), and if the pH value is close to the selected buffer, the "CFM" indicator will start blinking, otherwise the "WRONG" indicator, the pot and the BUF tags will start blinking.

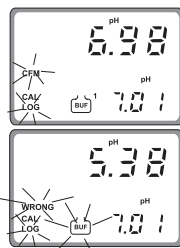

- Press the CFM key to confirm calibration. The meter will show the scrolling message "Press CFM again to confirm the current buffer or right to escape" (to prevent from confirming the calibration point inadvertently).



Pressing again CFM, the secondary LCD will display the second expected buffer value.

- In the second case (pH value not close to the buffer) the meter will remain in the same state until the reading becomes unstable or the calibration mode is quitted.
- For the second buffer value it is possible to choose between pH 4.01 and pH 10.01 (or pH 4.01 and pH 9.18 if the NIST set has been selected). Use the  $\square$  or  $\square$  key to switch between the two possibilities.
- Once selected the buffer, the procedure is the same as for the first calibration point.

**Note** A time-out of 2.5 minutes is present for the pH electrode response time. During calibration, if the pH reading is not stable after 2.5 minutes, the device displays twice the scroll-

ing message "time-out", then shows "WRONG" and it is not possible to complete calibration.

- At the end of calibration, with the meter set as pH controller, the instrument checks if the offset is between -30 and 30 mV and the slope between 53.5 and 62 mV/pH. If the values are not within these ranges, the message "Old Probe" scrolls twice across the LCD. The electrode is still working, but it is necessary to perform a cleaning procedure (see "Electrode conditioning and maintenance" and "In-line Cleaning" sections) or replace it.

If the offset is outside the -60 to 60 mV range, the "dEAd Probe" message will scroll across the LCD and the corresponding error is activated. The electrode has to be replaced as soon as possible because there is no reliability on the measured pH values.

### One-point calibration with manual selection of the calibration value.

A one-point calibration at a value different from the standard buffer values is possible by entering the desired calibration value. This is the actual pH value at the current calibration temperature.

- Enter the pH calibration mode (no matter if the standard or NIST buffer set is selected), then press (ALT+) SETUP while the secondary LCD is displaying the first buffer value (pH 7.01 or pH 6.86).



- The pH calibration value will switch to 7.00, the first digit starts blinking and it is possible to change its value simply using the  $\square$  or  $\square$  key.
- Once selected the first digit value, press the  $\square$  key: the first digit will be fixed and the second one will start blinking. Pressing of the  $\square$  key repeatedly will result on circularly moving on the secondary LCD.
- When the desired calibration value is reached (must be within 0.00 to 16.00 pH), press the CFM key to confirm and the calibration will proceed as described above.
- If the selected value is outside boundaries, the confirmation is not accepted and the first digit keeps blinking (waiting for confirmation of a valid value).

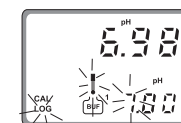

**Note** If (ALT+) SETUP are pressed instead of CFM, the calibration value selection is aborted and the meter reverts back to a two-point calibration.

**Note** Whenever a pH or ORP calibration is performed by means of **HI 504920**, the **HI 504920** date and time are automatically set in **HI 504910**.

## ORP CALIBRATION

Check that the code 90 has been entered in Setup mode.

To perform ORP calibration it is necessary to connect an **HI 931001** or **HI 8427** simulator to the BNC socket.

The meter has to be set as ORP controller.

- A two-point calibration has to be performed: the first point value is 0 mV and the second one can be chosen between 350 mV and 1900 mV.
- Enter the calibration mode, select the ORP calibration (use the  $\square$  and  $\square$  keys to move through setup menu) and press the CFM key.
- Set the **HI 931001** or **HI 8427** simulator to 0 mV.
- The primary LCD will display the current mV measure and the secondary LCD will show the first calibration point (0 mV).
- When the reading becomes stable, if the ORP value is close to the calibration point, the "CFM" indicator starts blinking; otherwise the "WRONG" indicator blinks and the "CAL" is fixed on.
- In the first case press CFM to confirm calibration. The meter will proceed showing the scrolling message "Press CFM again to confirm the current buffer or right to escape" (to prevent from confirming the calibration point inadvertently). Pressing again CFM the secondary LCD will display the second calibration point.
- In the second case (blinking "WRONG") the meter will remain in the WRONG state until the reading becomes unstable or the calibration mode is exited by pressing the CAL key.
- For the second calibration point it is possible to choose between 350 mV and 1900 mV. Pressing the  $\square$  or  $\square$  key the value on the secondary LCD will switch between the two possibilities.

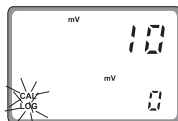

## TEMPERATURE CALIBRATION

- Once selected the second calibration point, set the **HI 931001** (350 mV) or **HI 8427** (350 or 1900 mV) simulator to the same value and the calibration proceeds as for the first point.

**Note** In ORP calibration there is no time-out.

**Note** Whenever a pH or ORP calibration is performed by means of **HI 504920**, the **HI 504920** date and time are automatically set in **HI 504910**.

Check that the code 90 has been entered in Setup mode.

- Prepare a beaker containing crushed ice and water at 0°C (32°F) and another one with hot water at 25°C (77°F) or 50°C (122°F).
- Use a Checktemp or another calibrated thermometer with a resolution of 0.1° as a reference thermometer.
- Immerse the temperature probe in the beaker with ice and water as near to the Checktemp as possible.



**Note** The instrument can support Pt100 or Pt1000 temperature sensor and calibration can be performed with anyone of these two probes.

- After entering the calibration mode, move through the menu (using the  $\square$  or  $\square$  key) to choose the temperature and the correct kind of used probe; the primary LCD shows "°C" and the secondary LCD gives indication about the kind of probe ("100" indicates a Pt100 probe, while "1000" stands for a Pt1000 probe).



Press the CFM key to confirm selection.



- The calibration has to be performed over two points: the first point has to be 0°C and the second one can be chosen between 25°C and 50°C.

Once confirmed the type of calibration, the primary LCD will display the current temperature measure and the secondary LCD will show the first calibration point (0°C).

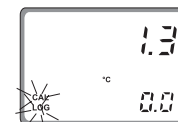

- When the reading becomes stable, if the temperature value is close to the calibration point the CFM tag starts blinking, otherwise the WRONG indicator will flash.
- In the first case press the CFM key to confirm calibration. The meter will proceed showing the scrolling message “Press CFM again to confirm the current buffer or right to escape” (to prevent from confirming the calibration point inadvertently).



- Pressing again the CFM key, the secondary LCD will display the second calibration point.
- In the case the measured temperature is not close to the calibration value, the meter remains in the WRONG status until the reading becomes unstable or the calibration mode is exited (by pressing the CAL key).
- When performing the second calibration point, it is possible to choose between two values, 25°C and 50°C. Pressing the  $\square$  or  $\square$  key the value on the secondary LCD will switch between the two possibilities.



- Once selected the value, immerse the temperature probe in the second beaker as near as possible to the Checktemp and the calibration procedure will be the same as for the first point.

## VOLT CALIBRATION

Check that the code 90 has been entered in Setup mode.

The instrument is factory calibrated; however the user may also perform the Volt calibration, which is a procedure available for the instrument configured as pH meter only.

During pH measurements the instrument reads a mV value from the electrode and then converts it into a pH value.

- Connect a **HI 931001** or **HI 8427** simulator to the BNC socket.

- Once entered the calibration mode, move through the menu with  $\square$  or  $\square$  key, select the Volt calibration (the primary LCD shows “UOLT” message) and confirm it by pressing the CFM key.

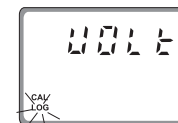

- After confirmation the primary LCD will show the actual mV value and the secondary LCD will display the first calibration point.

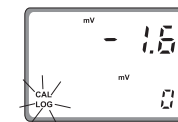

- The calibration is performed over two points, 0 mV and 350 mV.
- Set the **HI 931001** or **HI 8427** simulator to 0 mV.
- When the reading becomes stable, if the measured value is close to the calibration point the CFM tag starts blinking, otherwise the WRONG indicator will flash.
- In the first case press the CFM key to confirm calibration. The meter will proceed showing the scrolling message “Press CFM to confirm the current buffer or right to escape” (to prevent from confirming the calibration point inadvertently).
- Pressing again CFM the secondary LCD will display the second calibration point.
- Set the **HI 931001** or **HI 8427** simulator to 350 mV and follow the same procedure as for the first point.
- If the measured value is not close to the calibration value, the meter will remain in the WRONG status until the reading becomes unstable or the calibration mode is exited (by pressing the CAL key).

## SETUP MODE

The Setup Mode allows the user to set all needed characteristics of the meter.

Press (ALT+) SETUP and enter the password when the device is in idle or control mode.



If the correct password is not entered, the user can only view the setup parameters (except for passwords) without modifying them (and the device continues to acquire and transmit measurements).

To each setup parameter (or setup item) is assigned a three characters (one letter followed by two digits) setup code which is entered and displayed on the secondary LCD. The first character identifies the group of setup items, while the two digits identify the particular item within that group.

The setup codes can be selected after password is entered and CFM key is pressed. When CFM is pressed, the current setup item is saved on EEPROM and the following item is displayed.

The possible transitions in setup mode are the following:

### ENTERING THE PASSWORD

- Press (ALT+) SETUP to enter the setup mode. The primary LCD will display "0000", while the secondary LCD shows "PAS". The first digit of the primary LCD will blink.
- Enter the first digit of the password by using the  $\square$  or  $\square$  key.
- Then move to the next digit with  $\square$  and enter a digit as described above. Continue for the last two digits.
- When the whole password has been inserted, press CFM to confirm it.

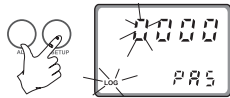

**Note** The default password is set at "0000".

### ENTERING SETUP ITEMS

After confirmation of the password the primary LCD will show the name of the first setup group (see table) while the secondary LCD will display the setup code of the first item of the group.

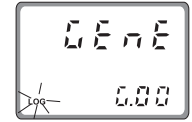

- By pressing the  $\square$  or  $\square$  key it is possible to cycle through the setup groups; the secondary LCD will always show the code of the first item of the group.



- Once a group is selected, it is possible to choose an item manually. Pressing the  $\square$  key, the first digit of the setup code will start blinking. Now it is possible to change its value by pressing the  $\square$  or  $\square$  key.
- Pressing the  $\square$  key again, the first digit will be fixed while the second digit starts blinking and its value can be changed as described above.

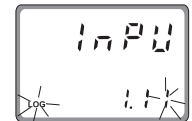
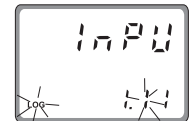

- By pressing the  $\square$  key again all the digits will be fixed.
  - If CFM key is pressed, the selected item is confirmed; the secondary LCD will show the setup item code while the primary LCD will display the current item value.
- If a fixed set of values is available for the selected item, use the  $\square$  or  $\square$  key to switch between them.

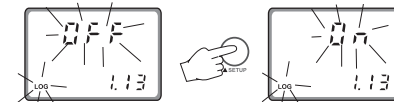

Otherwise, if a numeric value has to be entered for the item, use the  $\square$  or  $\square$  key to change the value of the blinking digit and the  $\square$  key to cycle through the number's digits.

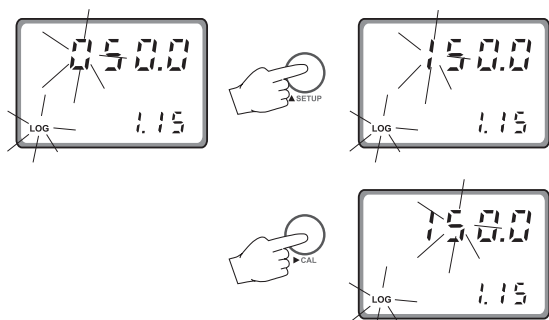

- Once a value is set, press the CFM key to confirm. The instrument will turn to the next item and the new item's value will be displayed on the primary LCD.
- If a wrong value is confirmed, the WRONG indicator starts blinking, the new value is not accepted and the instrument will not switch to the next item until a correct value will be confirmed.
- Instead of selecting the item manually, it is possible to cycle through all the items of a selected group by pressing repeatedly CFM key. The procedure to modify the item's value is the same described above.

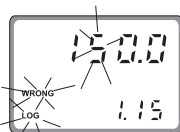

If the last item of the group is reached, by pressing the CFM key again the primary display will show the group name and it will be possible to change the group by pressing the  $\square$  or  $\square$  key.

**Note** At any time for exiting the setup mode press (ALT+) SETUP. If no modification has been confirmed, no setup item is changed.

**Note** While in the setup mode, if no activity is performed for about 5 minutes after entering the setup mode, the mode is automatically exited and the instrument returns to the previous mode.

The following table lists the setup codes along with the description of the specific setup items, their valid values and whether the item is present for ORP mode.

Code	Valid Values	Default	Present for ORP
<b>GENERAL ("GenE")</b>			
G.00 pH/ORP input	"PH", "Orp" (see note 4)	"PH"	yes
G.01 Temperature compensation	"AtC": Automatic "USEr": Manual (see note 3)	"AtC"	no
G.02 Manual or probe error temperature	-30 to 130.0 °C (see note 3)	25.0	no
G.10 Factory ID	0000 to 9999 (see note 9)	0000	yes
G.11 Instrument ID alias RS485 address	00 to 99 (see note 9)	00	yes
G.98 Calibration password	0000 to 9999 (see notes 1, 9)	0000	yes
G.99 General password	0000 to 9999 (see notes 1, 9)	0000	yes
<b>OUTPUT ("OutP")</b>			
O.30 Baud rate (see notes 9, 13)	1200, 2400, 4800, 9600, 19200	2400	yes
O.31 Modem calls answer enable (see note 9)	"OFF": disabled "On": enabled	"OFF"	yes
O.32 Modem country code (see note 14)	Dialing code of a country where the modem of <b>H1504902</b> is certified	"000"	yes
<b>INPUT ("InPU")</b>			
I.11 Life check time (see note 5)	"OFF": life check disabled 1: 1 hour; 2: 2 hours; 4: 4 hours	"OFF"	yes
I.12 Minimum pH probe slope	45 to 75 mV/pH	45 mV/pH	no
I.13 pH electrode impedance test enable (see note 10)	"OFF": disabled "On": enabled	"On"	no
I.14 Reference electrode impedance test enable	"OFF": disabled "On": enabled	"On"	yes
I.15 Max ref. electrode impedance	0.5 to 100.0 k $\Omega$	50.0 k $\Omega$	yes
I.17 Mains frequency (see note 11)	50 or 60 Hz	50 Hz	yes
<b>REAL TIME CLOCK ("rtC")</b>			
r.00 Current day	01 to 31 (see note 9)	from RTC (see note 12)	yes
r.01 Current month	01 to 12 (see note 9)	from RTC (see note 12)	yes
r.00 Current year	2000 to 2099 (see note 9)	from RTC (see note 12)	yes
r.00 Current time	00:00 to 23:59 (see note 9)	from RTC (see note 12)	yes

Code	Valid Values	Default	Present for ORP
<b>CELLULAR/MODEM/PC CONNECTION ("PHOn")</b>			
P00 RS485 connection type (see note 9)	"PC" = PC or modem connection "CELL" = cellular module connection	"PC"	yes
P01 PIN number (see note 9)	0000 to 9999	0000	yes
<b>READING OFFSETS ("OFFS")</b>			
F00 pH or ORP actual value (see note 7)	measured value -1.00 pH or -200 mV to measured value +1.00 pH or +200 mV	measured value	yes
F01 pH or ORP reading offset adjustment	-1.00 to +1.00 pH or -200 to +200 mV	0.00 pH or 0 mV	yes
F10 Temperature actual value (for ATC only, see note 8)	measured value -10.0 °C to measured value +10.0 °C	meas. value (see note 7)	no
F11 Temperature reading offset adjustment (for ATC only, see note 8)	-10.0 to +10.0 °C	0.0 °C	no
<b>TEST ("tESt")</b>			
t.00 Display test	"OFF": To skip without testing	"OFF"	yes
t.02 EEPROM test	"GO": To start the display test		
t.03 LEDs test			

## Notes

- (1): The calibration password allows only calibrations, while the general password allows everything (including calibration). Obviously, the general password and the calibration password cannot be viewed among other items when the "SETUP" key is pressed without entering the right general password. The instrument is sold with a "0000" general password.
- (2): When a wrong setup value is confirmed, the instrument does not skip to the next setup item, but remains in the current item displaying a blinking "WRONG" indicator till the parameter value is changed by the user (the same thing happens also for the setup code selection).
- (3): See the "Temperature compensation" subsection for more details on how the Automatic temperature compensation and Manual temperature compensation work.
- (4): Whenever the pH/ORP selection item is changed from pH into ORP or vice versa all of the calibration and setup data regarding pH (when changing to ORP) or ORP (when changing to pH) are kept. They are automatically restored if the mea-

sured magnitude is changed back later. The following setup items cannot vary when changing from pH to ORP or vice versa (because they are items strictly related to the instrument and not to the measured magnitude): Factory ID, Instrument ID alias RS485 address, Calibration password, General password, Baud rate, Modem calls answer enable and Mains frequency.

(5): A life check error is generated if the pH reading does not vary for more than  $\pm 0.10$  pH within the time selected through the "life check time" item (for pH) or mV reading for more than  $\pm 10$  mV within the same time (for ORP).

(6): When the instrument is configured for ORP measurements, some of the above items or item values are not anymore available to the user.

(7): "measured value" is the reading value with a null reading offset adjustment.

(8): If the device is set for MTC (item G.01 to "USER") then items F.10 and F.11 cannot be modified nor seen. When item G.01 is changed from "AtC" into "USER", item F.11 is automatically zeroed.

(9): These items do not vary when the pH/ORP input selection ("G.00") is changed.

(10): This item must be set to "OFF" when an amplified electrode is in use.

(11): Select the frequency of the mains power supply in your country. This value is used to filter mains power supply noise when performing the pH/ORP probe check.

(12): When the instrument is powered, RTC is checked to see if an RTC reset occurred since last software initialization (if one even took place). If this is the case, the RTC is initialized with the default date and time: 01-01-2000-00:00. An EEPROM reset does not affect the RTC settings.

(13): **Only 2400 can be used for connection to HI 504.**

(14): The modem present in the **HI 504902** module is certified by Telecom to work in the following countries: Argentina, Australia, Austria, Belgium, Brazil, Canada, Chile, China, Cyprus, Czech Republic, Denmark, Finland, France, Germany, Greece, Hong Kong, Hungary, Iceland, India, Indonesia, Ireland, Israel, Italy, Japan, Korea, Liechtenstein, Luxembourg, Malaysia, Mexico, Netherlands, New Zeland, Norway, Philippines, Poland, Portugal, Russia, Singapore, Slovak Republic, South Africa, Spain, Sweden, Switzerland, Taiwan, Turkey, United Kingdom, United States.

If your country is not present in the list, please contact your Hanna dealer.

If the country code is shorter than 3 characters, fill the code with zeros in front.

## MEASURE MODE

---

The measure mode is the normal mode for the instrument. During measure mode, pH and temperature or ORP measurements are acquired and sent to **HI 504** or to a PC with **HI 92500** or another software implementing the communication protocol described in this manual (see the "RS485 communication section").

In a normal situation, during measure mode the green LED is ON and the red LED is OFF (LEDs are located inside the instrument case).

When the Setup mode or the Calibration mode are entered through the **HI 504920** (or through the **HI 504910** internal keyboard), both the green and the red LEDs are ON. The red LED ON warns the user that the **HI 504910** is not measuring and transmitting measurements.

**Note** In this situation, **an HI 504 connected to HI 504910 will be in hold mode.**

In case of an error occurs in **HI 504910**, the green LED turns OFF and the red LED flashes.

**Note** When measurements are in overflow, the internal LCD of the **HI 504910** or that of **HI 504920** (in terminal mode) will show the blinking upper or lower boundary value.

## ERRORS

---

When an error occurs, the green LED turns OFF and an alarm indication is given by the flashing red LED.

Below are listed all the errors with the correspondent error code.

The error code is reported in the event log file, which can be examined by means of the DISPLAY key while in normal measure mode (see the "Event log file scrolling" section). This is necessary for identifying which error is active and makes the red LED flash.

- **Life check error (03)** : The pH reading did not vary more than  $\pm 0.10$  pH (for pH) or the mV reading did not vary more than  $\pm 10$  mV within the time selected through the "Life check time" setup item (I.11).

Clean and check the electrode.

- **pH electrode broken or leakage (10)** : The electrode glass is broken or short circuits have been caused by moisture or dirt.  
Check pH probe and cable; replace them if necessary.
- **Reference electrode broken or dirty (11)** : The reference electrode is soiled or broken. Also the reference electrode or the matching pin could not have been immersed in the solution.  
Clean the electrode and replace it when necessary.
- **Old pH probe (12)** : The pH probe is old (offset outside of  $\pm 30$  mV or slope outside the range 53.5 to 62 mV/pH). The electrode is still working, but it is recommended to clean or replace it.
- **Dead pH probe (13)** : Offset is outside of  $\pm 60$  mV or slope outside the range 40 to 70 mV/pH. Readings are not reliable.  
Try to clean the probe; if the error persists after cleaning, replace the probe immediately.
- **No calibration (14)** : The device has lost its calibration due to an EEPROM reset.  
Calibrate again all the magnitudes.
- **Temperature probe broken (20)** : Check the temperature probe wires and connections.  
Replace the probe if necessary.
- **Cellular error (50)** : This is an error related to the **HI 504900** GSM module. Check the power supply for **HI 504900**. Verify that the signal coverage is good.
- **Power reset (90)** : The device was restarted due to a power failure.
- **EEPROM corruption (91)** : The EEPROM data is damaged. Reset the EEPROM, then recalibrate and reconfigure completely the instrument.
- **Watchdog reset (92)** : The device was restarted due to a watchdog reset or a manual reset done through the keyboard.

## pH/ORP PROBE CHECK

The pH electrode and the reference electrode for both pH and ORP can be automatically monitored through **HI 504910**.

Setup items involved are I.13 (pH electrode impedance test enable), I.14 (reference electrode impedance test enable) and I.15 (maximum reference electrode impedance).

A “pH electrode broken or leakage error” (error code: 10) is generated whenever the pH electrode impedance is less than 1 M $\Omega$ . This error can be due to breakage of the electrode glass or short circuits caused by moisture or dirt.

A “reference electrode broken or dirty or not immersed” error (error code: 11) is generated whenever the reference electrode impedance is greater than the value set in item I.15 (maximum reference electrode impedance range is 0.5 to 100.0 K $\Omega$ , default is 50.0 K $\Omega$ ). This error can be due to soiling of the reference electrode. It can occur also when the reference electrode or the matching pin are not immersed in the solution.

The pH electrode test is performed when the following conditions are satisfied:

- the test has been enabled through the setup item I.13;
- the device is in one of the following modes: measure, last calibration data scrolling, event log file scrolling;
- the device is configured to measure pH.

**Note** If an amplified electrode is used, the pH electrode test must be disabled by the user through the setup item I.13.

The reference electrode test is performed when the following conditions are satisfied:

- the test has been enabled through the setup item I.14;
- the device is in one of the following modes: measure, last calibration data scrolling, event log file scrolling.

**Note** When testing or calibrating the instrument through a pH/ORP simulator like HI 931001 or HI 8427, temporarily set the item I.13 to “OFF” and short the Matching pin and the Reference pin terminals.

## TEMPERATURE COMPENSATION

If the setup item G.01 is set to “AtC” an automatic temperature compensation will be performed using the temperature value acquired with the Pt100/Pt1000 input.

If the probe appears to be unconnected, or anyway it does not give a valid temperature (temperature outside the -30 to 130°C range), the instrument will generate a broken temperature probe error. In this case the temperature will be automatically set to the setup item G.02 (“Manual or probe error temperature”) and the setup item G.01 will be automatically set to “USEr” (see below).

After that, the Pt100/Pt1000 input continues to be monitored to track the Pt100/Pt1000 error closing.

The setup item G.01 is automatically changed back to “AtC” when the Pt100/Pt1000 error is closed.

During error condition, if the user decides to start working in manual mode (and so manually close the error), he has to go in setup menu (item G.01), change the value to “AtC” (automatic compensation) without giving confirmation, then change again to “USEr” and finally give confirmation by pressing the CFM key.

If the setup item G.01 is set to “USEr” a manual temperature compensation will be performed, no matter whether the temperature probe is connected to the Pt100/Pt1000 input or not. The start value for temperature, when entered the manual mode, is the one stored at G.02 (“Manual or probe error temperature”).

If the user wants to change the temperature value while in manual mode, he has to press the  $\square$  or  $\square$  key. Pressing once the  $\square$  key it will add 0.1°C to the actual temperature value, while pressing the  $\square$  key it will subtract 0.1°C.

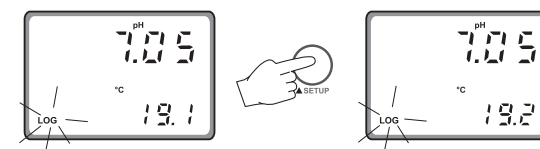

During these operations both the temperature value displayed and setup item G.02 are updated (the last one is updated with a maximum delay of 10s).



## LAST CALIBRATION DATA

If the instrument is set as pH meter, the following data about the last calibration are stored in the EEPROM:

- Date
- time
- offset, in mV
- slope, in mV/pH
- up to two buffers.

If the instrument is set as ORP meter, the data stored in the EEPROM are the following:

- Date
- time
- first calibration point
- second calibration point.

While displaying these data the **HI 504910** continues to acquire and transmit measurements.

To enter the last calibration data mode, press (ALT+) CAL DATA.

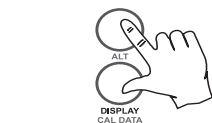

If the meter has never been calibrated or an EEPROM reset has occurred, no calibration data is shown when CAL DATA is pressed. The “no CAL” message will blink for a few seconds, then the meter skips back to the previous mode.

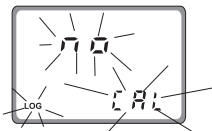

If the meter is configured to measure pH, once entered the last calibration data, the following messages could scroll twice on the primary LCD before showing the calibration date:

- “Old probe”
- “Dead probe”.

Otherwise the last calibration date will appear on the primary LCD displayed as DD.MM format, while the secondary display will show the last two digit of the year.



Pressing the  $\square$  key, the meter will cycle through the following steps in reverse order, i.e. beginning from last buffer.

**Note** At any time pressing the DISPLAY key or (ALT+) SETUP keys the meter will return to the regular operating display.

- Press the  $\square$  or  $\square$  key to view the time of last calibration. The secondary display will show “HOU” to indicate “hour and minute” while the primary LCD will show the time as HH:mm format.

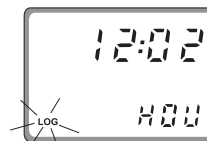

- Press the  $\square$  or  $\square$  key again to view the offset in mV at the time of last calibration. The secondary display will show “OFF” to indicate “offset”.

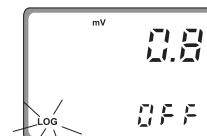

- Press the  $\square$  or  $\square$  key again to view the slope in mV/pH at the time of last calibration. The secondary display will show “SLO” to indicate “slope”.

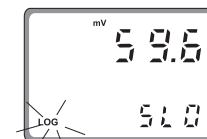

- Press the  $\square$  or  $\square$  key again to view the first memorized buffer at the time of last calibration. The secondary display will show “BUF1” to indicate “first buffer”.

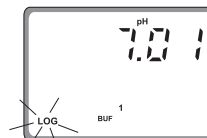

- Press the  $\square$  or  $\square$  key again to view the second memorized buffer (if present) at the time of last calibration. The secondary display will show “BUF2” to indicate “second buffer”.

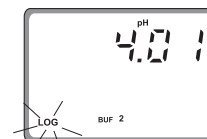

- Press the  $\square$  or  $\square$  key again to return to the first CAL DATA display (date) at the time of last calibration.



## OFFSET AND SLOPE DIRECT SELECTION

It is possible to edit directly the values of the offset and the slope to calibrate the instrument (for pH).

- Press (ALT+) CAL DATA entering the last calibration data scrolling and then press (ALT+) SETUP.



- A password entry is required. If a wrong password is confirmed, the instrument reverts back to the normal mode.

- Otherwise, if correct password is confirmed, the LCD will appear as follows: the secondary LCD shows "OFF" to indicate "offset" while the primary one shows offset default value. The first digit on the primary LCD is blinking, and it is possible to change it by pressing  $\square$  or  $\square$  key.

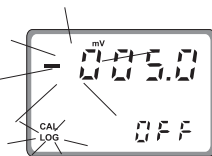

- Pressing the  $\square$  key will move to the second digit while the first one will be fixed.

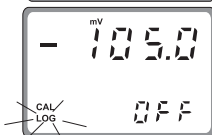

- Pressing repeatedly the  $\square$  key will move cyclically through the digits of the primary LCD.

- Once selected the desired value, press CFM to confirm the calibration offset.

- If the offset is invalid, the "WRONG" indicator will blink on the display.

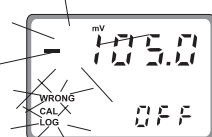
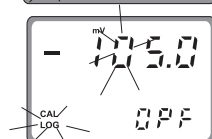

**Note** If DISPLAY or (ALT+) CAL DATA are pressed before CFM, calibration is aborted without changing the previous calibration data.

- If an offset calibration has been made, the instrument will turn to "slope" calibration (as indicated by the "SLO" message on the secondary display). The slope value is shown on the primary LCD and the first digit is blinking to permit modifications).

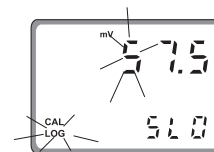

- Press the  $\square$  or  $\square$  key to modify the value or  $\square$  key to move to the next digit.
- Once selected the desired value, press CFM to confirm.
- After confirmation the instrument will turn back to normal mode.
- If the slope is invalid, the "WRONG" indicator will blink on the LCD.

**Note** Press DISPLAY or (ALT+) CAL DATA to exit calibration. The slope will be set to the default value (57.5 mV/pH).

**Note** After direct selection of offset and slope, calibration data can be viewed by pressing (ALT+) CAL DATA while in normal mode, but no pH-buffer values will be displayed during the data scrolling on the LCD.

**Note** Whenever a pH or ORP calibration is performed by means of HI 504920, the HI 504920 date and time are automatically set in HI 504910.

## EVENT LOG FILE SCROLLING

The event log file is composed of maximum 100 recorded events, which include errors, calibration events (type of calibration, date, time) and configuration changes.

To enter the event log file scrolling, press the DISPLAY key while in normal measurement mode. Event scrolling does not affect acquisition and transmission of measurements, which continue normally.

If there is no event in the event log file, nothing happens when the DISPLAY key is pressed.

Otherwise the primary display will show the code of the last logged event while the secondary LCD will show the number (index) of the event.

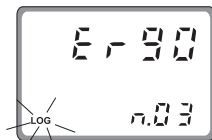

For each event the following is reported in any case:

- error code (displayed "Er" followed by the error number) or setup item code (displayed "S" followed by the setup item code) or "CALE" indication;
- event index (the oldest event has index 0, the latest event has the higher index) shown on the secondary LCD.

In addition, the following information can be visualized:

- for errors:
  - start date
  - start time

and if error is not on anymore:

- end date
- end time.

- for configuration changes:

- date of change
- time of change
- previous value
- new value

- for calibrations:

- date of calibration
- time of calibration
- calibrated unit ("pH", "OrP", "°C", "UoLr")

Once entered the log event scrolling, press the  $\square$  or  $\square$  key to move through the events.

If the event is an error still active, the error code on the primary LCD will blink, otherwise it will be fixed.

To have a look at the additional information of a selected event press the  $\square$  key (it will cycle through the additional information).

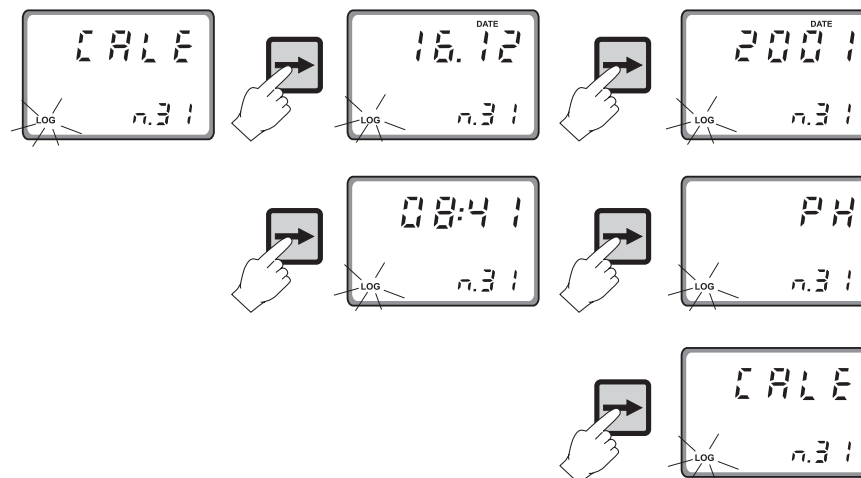

**Note** To exit the log event scrolling, press the DISPLAY key.

**Note** The logged event information can be downloaded to a PC through the **HI 92500** application software.

## FAULT CONDITIONS

The below fault conditions may be detected by the software:

- EEPROM data error
- serial communication internal bus failure
- dead loop.

EEPROM data error can be detected through EEPROM test procedure at start-up or when explicitly requested using setup menu, or during normal operational mode if a checksum control fails.

When an EEPROM error is detected during normal mode, a fault alarm is generated.

To close an error an EEPROM test (see "Selftest procedures" section) or reset is required.

As soon as an EEPROM error is detected, the scrolling message "EEPROM reset needed - Press up button to reset stored data or right button to ignore" will appear on the primary LCD.

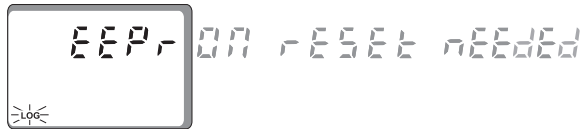

If the  $\square$  key is pressed, the instrument restarts operation, but the device will be in Hold mode in any case (i.e. no measurement will be acquired).

If the  $\square$  key is pressed, all the data stored in the EEPROM are erased and the default values loaded. After that, the device must be completely recalibrated.

An internal bus error is detected when internal transmission is not acknowledged or a bus fault occurs for more than a certain number of unsuccessful transmission attempts (due for example to a damage occurred to one of the ICs connected to the internal bus). After that the controller displays a sliding message "Serial bus error".

If the error is due to impossible communication, all the instrument tasks are stopped, the red LED blinks and the "Serial bus error" slides forever (repair can not be postponed).

A software watchdog is provided in order to detect dead loop conditions or other causes that make the software stuck. If it happens, a software reset is generated after a time-out of 1 second.

## RS485 COMMUNICATION

The digital transmission of measurements, error and status information is implemented through an RS485 link.

The transmission can be directed to an **HI 504** or to a computer workstation, which can be connected locally or remotely through a modem connection.

RS485 standard is a digital transmission method that allows long lines connections. Its current-loop system makes this standard suitable for data transmission in noisy environments.

Data transmission from the instrument to the PC is possible with the **HI 92500** Windows® compatible application software offered by Hanna Instruments and an RS232 to RS485 adapter with Send Data Control connected to the serial port of your PC.

The user-friendly **HI 92500** offers a variety of features such as logging selected variables or plotting the recorded data. It also has an on-line help feature to support you throughout the operation.

The readings logged into the **HI 504910** internal memory can be downloaded through **HI 92500**.

**HI 92500** makes it possible for you to use the powerful means of the most diffused spreadsheet programs. Simply run your favorite spreadsheet program and open the file downloaded by **HI 92500**. It is then possible to elaborate the data with your software (e.g. graphics, statistical analysis).

To install **HI 92500** you need a 3.5" drive and few minutes to follow the instructions conveniently printed on the disk's label.

Contact your Hanna Dealer to request a copy.

## SPECIFICATIONS

The RS485 standard is implemented in **HI 504910** with the following characteristics:

<b>Data rate:</b>	up to 19200 bps (manually selected)
<b>Communication:</b>	Bidirectional Half-Duplex
<b>Line length:</b>	up to 1.2 km typ. with 24AWG cable
<b>Loads:</b>	up to 32 typ.
<b>Internal termination:</b>	none

 Only 2400 bps can be used for connection to **HI 504**.

Windows® registered Trademark of "Microsoft Co."

## CONNECTIONS

The connections for the 2-pin RS485 terminal provided are as follows:

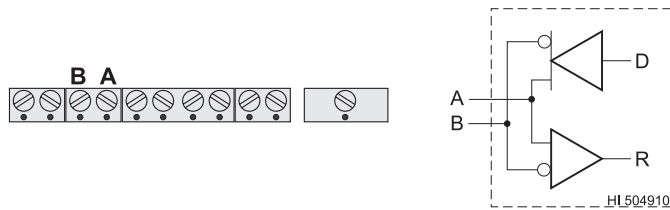

The instrument has no internal line termination. To terminate the line, an external resistor equal to the characteristic line impedance (typically 120Ω) must be added at both ends of the line.

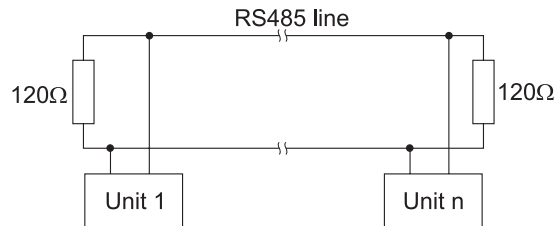

The RS485 can connect up to 31 Digital Transmitters on the same physical network. All the units are slave devices and are monitored and controlled by a single master station (typically an industrial PLC or PC).

Each unit is identified by its RS485 address, included in the 00 to 99 interval, which corresponds to the Instrument ID configured through the setup item G.11.

(If the instrument does not recognize the address within the command string, then it discards all the following bytes).

To avoid erroneous readings in Open-Line conditions, pull-up and pull-down resistors should be connected as shown (Fail Safe Open Line protection method).

The Fail-Safe resistors are connected only to one unit in the line, and their value depends on the application and characteristic impedance of the connection cable.

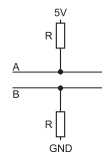

If using **HI 504** the fail safe resistors are already connected on it, so they are necessary only if the **HI 504910** transmitter is connected to a PC.

The interface signals are optoisolated from the ground of the instrument, the electrode and the temperature sensor.

Before connecting the meter to the computer, consult the computer manual.

The instrument can only work as a slave component. In other words it can work as a remote terminal equipment answering to the commands only.

## RS485 PROTOCOL

This section is useful when connecting the **HI 504910** transmitter to a computer workstation or PLC, and an user-software is used instead of **HI 92500**.

Commands are composed of four parts: addresses, command identifier, parameter, end of command.

Some of the commands are used when the master is requesting information from the controller, other when the master wants to set a parameter in the instrument memory (RAM or EEPROM).

The end of commands corresponds to the CR char (0x0d).

The master software must send the command string with a maximum delay of 20 ms between each character.

The program on the master must not allow setting commands other than keyboard commands if the general password has not been entered. After the general password recognition through the "PWD" command, a 1-minute time-out is let before the instrument locks again, i.e. if the PC program waits for more than 1 minute between two subsequent setting commands, the second one is not fulfilled and the "PWD" command must be issued again.

Following is the complete list of commands available:

Command	Parameter	Remarks
NNMDR	not available	Requests firmware code (always available)
NNSTS	not available	Requests instrument status (LEDs, configuration change flag, etc.)
NNPHR	not available	Requests last pH reading (instrument configured for pH)
NNMVR	not available	Requests last mV reading (always available)
NNTMR	not available	Requests temperature reading (always available)
NNCAR	not available	Requests all last calibration data (always available)
NNGET	CNN	Requests setup item C.NN
NNPWD	C <sub>1</sub> C <sub>2</sub> C <sub>3</sub> C <sub>4</sub>	Sends the general password (always available)
NNSET	CNNP <sub>1</sub> P <sub>2</sub> C <sub>1</sub> C <sub>2</sub> C <sub>3</sub> C <sub>4</sub>	Sets setup item C.NN with parameter P <sub>1</sub> P <sub>2</sub> C <sub>1</sub> C <sub>2</sub> C <sub>3</sub> C <sub>4</sub> (*) (not available in setup mode)
NNEVF	not available	Requests event log file (always available)
NNEVN	not available	Requests new events (always available)
NNAER	not available	Requests active errors (always available)
NNKDS	null	Same as LCD key
NNKCD	null	Same as CAL DATA key
NNKUP	null	Same as $\square$ key
NNKRG	null	Same as $\square$ key
NNKST	null	Same as SETUP key
NNKCL	null	Same as CAL key
NNKDW	null	Same as $\square$ key
NNKCF	null	Same as CFM key

(\*) C<sub>1</sub>C<sub>2</sub>C<sub>3</sub>C<sub>4</sub> are ASCII chars corresponding to the setup item content; P<sub>1</sub>P<sub>2</sub> are two additional bytes used for sign and half digit as follows:

P <sub>1</sub>	=	+	if > 0
P <sub>1</sub>	=	-	if < 0
P <sub>2</sub>	=	0	if most significant digit is not used
P <sub>2</sub>	=	1	if most significant digit is used

When an item is shorter than 4 digits the C<sub>i</sub> characters are filled with blanks.

Following are examples for setup item format:

- item I.12, minimum pH probe slope: parameter value = 56.2 mV, format = "+0562◇◇", where ◇ indicates a blank;
- item F.11, temperature reading offset adjustment: parameter value = -0.3°C, format = "-0003";
- item G.01, temperature compensation: parameter value = "AtC", format = "+0\*AtC".

For all items with a fixed set of choices, blank spaces on the left of the value displayed are replaced with "\*" (as many "\*" characters are needed to reach the maximum string length, which is for example 3 for item I.11).

Blanks must be put on the tail for all items in order to have always a total length of 6 characters (see the setup table).

The same parameter format used for setup item setting is used also for setup item getting (i.e. when a "NNGETCNN<CR>" command is received from the PC, the reply "NN<STX>P<sub>1</sub>P<sub>2</sub>C<sub>1</sub>C<sub>2</sub>C<sub>3</sub>C<sub>4</sub><ETX>" is sent back).

To perform a "NNSETCNN..." command the general password has to be sent in advance through the "NNPWD..." command. See above for the password effectiveness time-out.

Some special setup items can not be set through RS485 commands. In particular it is not possible to access any setup item that performs a test on the instrument and it is not possible to configure the baud rate (setup item O.30).

The "NNSET..." and "NNGET..." commands when used for password items, baud rate, F.00 and F.10 items, are answered with "NN<CAN>".

As soon as the instrument realizes that a command has been received, it sends one of the following answers:

- 1) "NN", ACK (char 0x06) if the instrument recognizes the set command and performs the requested task;
- 2) "NN", STX (char 0x02), DATA, ETX (char 0x03) if the received command is a request of data;
- 3) "NN", NAK (char 0x15) if the instrument does not recognize the command or if the command syntax is wrong;
- 4) "NN", CAN (char 0x18) if the instrument can not answer to the request (because the given general password is wrong, etc.)

**The "NN" in the front of the answer is the Instrument ID ("00" to "99").**

The time-out for the above answers is:

- 1) answer to "STS", "PHR", "MVR", "TMR", "AER" commands: 30 ms @ 19200 or 9600 bit/s, 40 ms @ 4800 bit/s, 60 ms @ 1200 bit/s (for the complete answer, from STX to ETX).
- 2) answer to other commands: 2s (for the first character of the answer).

The minimum delay between the last received and the first sent character is 15 ms to allow the master to set itself into receiving mode.

Here are descriptions of the answers format (for setup item request see above):

The **NNMDR** request produces the following answer:

"NN<STX>FP504910W-ABCD<ETX>"

where VV is the firmware version, e.g. "10" for 1.0 and ABCD is a special code used by **HI 92500**.

The **NNPHR**, **NNMVR**, **NNTMR** requests produce the following answer:

"NN<STX><ASCII string for a float>N<ETX>".

The answer to the **NNSTS** command is:

"NN<STX>C<sub>1</sub>C<sub>2</sub>C<sub>3</sub>C<sub>4</sub><ETX>"

where C<sub>1</sub>C<sub>2</sub> are the ASCII representation of byte B<sub>1</sub> described below (e.g. B<sub>1</sub> = 0xF3 □ C<sub>1</sub> = "F", C<sub>2</sub> = "3"), C<sub>3</sub>C<sub>4</sub> are the ASCII representation of byte B<sub>2</sub> described below (e.g. B<sub>2</sub> = 0x1D □ C<sub>3</sub> = "1", C<sub>4</sub> = "D").

The meaning of B<sub>1</sub> and B<sub>2</sub> is:

B <sub>2</sub>	bit 0	green LED (1 : ON; 0 : OFF)
B <sub>2</sub>	bit 1,2	red LED (bit 2 = 0 and bit 1 = 0: LED is OFF; bit 2 = 1 and bit 1 = 0: LED is fixed ON; bit 2 = 1 and bit 1 = 1: LED blinks)
B <sub>2</sub>	bit 3	free for future use (and set to 0)
B <sub>2</sub>	bit 4	free for future use (and set to 0)
B <sub>2</sub>	bit 5	free for future use (and set to 0)
B <sub>2</sub>	bit 6	free for future use (and set to 0)
B <sub>2</sub>	bit 7	free for future use (and set to 0)
B <sub>1</sub>	bit 0	free for future use (and set to 0)
B <sub>1</sub>	bit 1,2	setup mode (bit 2=0 and bit 1=0: not in setup mode; bit 2=1 and bit 1=0: setup mode, view only; bit 2=1 and bit 1=1: setup mode, unlocked)
B <sub>1</sub>	bit 3	calibration mode with device unlocked (1 : yes, 0 : no)
B <sub>1</sub>	bit 4	setup updated (set to 1 after a device power-up or a device reset or a change in setup made through the instrument keyboard; reset to 0 after receiving a GET command)
B <sub>1</sub>	bit 5	calibration made (set to 1 after a device power-up or whatever complete calibration; reset to 0 after receiving a CAR command)
B <sub>1</sub>	bit 6	hold mode (1 : ON, 0 : OFF)
B <sub>1</sub>	bit 7	free for future use (and set to 0)

The **NNCAR** request produces the following answer:

#### 1) **Instrument configured for pH:**

If pH is not calibrated: "NN<STX>0<ETX>"

If calibration has been performed: "NN<STX>1 *date time offset slope1 slope2 buf1 buf2* N<ETX>"

The items in italic are separated by blank spaces and have the following formats:

<i>date</i>	ddmmyy	("020498" for April 2, 1998)
<i>time</i>	hhmm	("1623" for 4:23 pm)
<i>offset</i>	ASCII string for a float	(example: "-0.2")
<i>slope1</i>	ASCII string for a float	(example: "62.5")
<i>slope2</i>	ASCII string for a float	(example: "60.4")

*buf1* ASCII string for a float (example: "7.01")

*buf2* ASCII string for a float (example: "4.01")

When some of the above items is missing (for example *buf3* when a 2-point calibration is performed) it is indicated with a "N" letter.

## 2) Instrument configured for ORP:

If mV is not calibrated: "NN<STX>0<ETX>"

If calibration has been performed: "NN<STX>1 *date time* NNN  
*buf1 buf2* N<ETX>"

The items in italic are separated by blank spaces and have the following formats:

*date* ddmmyy ("020498" for April 2, 1998)

*time* hhmm ("1623" for 4:23 pm)

*buf1* ASCII string for a float (example: "0")

*buf2* ASCII string for a float (example: "1900")

None of the items above can be missing when the Instrument is configured to measure and control ORP (as it always has to be calibrated on two points).

The event log file is requested through the **NNEVF**<CR> command. The maximum length of the event log file is 100 records. Here is the format for the answer:

If there is no generated error or event, the answer has the format "NN<STX>0<ETX>", otherwise:

"NN<STX>*events\_no event\_code<sub>1</sub> start\_date<sub>1</sub> start\_time<sub>1</sub> end\_date<sub>1</sub> end\_time<sub>1</sub> desA<sub>1</sub>desB<sub>1</sub>...*

*event\_code<sub>2</sub> start\_date<sub>2</sub> start\_time<sub>2</sub> end\_date<sub>2</sub> end\_time<sub>2</sub> desA<sub>2</sub>desB<sub>2</sub>...*

*event\_code<sub>m</sub> start\_date<sub>m</sub> start\_time<sub>m</sub> end\_date<sub>m</sub> end\_time<sub>m</sub> desA<sub>m</sub>desB<sub>m</sub> <ETX>"*

where *m* is the number of events. Each token is followed by a blank space, except the last one ("desB<sub>*m*</sub>"), directly followed by the <ETX> character.

"events\_no" is the number of events and its format is the ASCII format for a number ("1", "2"... "99", "100").

The meaning of "start\_date<sub>*i*</sub>" and "start\_time<sub>*i*</sub>" is:

- for errors: date and time at which the error was generated;
- for setup events: date and time of a setup item change;

- for calibration events: date and time of a calibration.

The meaning of "end\_date<sub>*i*</sub>" and "end\_time<sub>*i*</sub>" is:

- for errors: end date and time if the error is not active anymore;
- for setup events: no meaning;
- for calibration events: no meaning.

The tokens format is described here below:

<i>event_code<sub>i</sub></i> (errors)	ERNN	(e.g. "ER01" for Setp.1 alarm)
<i>event_code<sub>i</sub></i> (setup)	SCNN	(e.g. "Sr01" for current month)
<i>event_code<sub>i</sub></i> (calibration)	CALE	(always the string "CALE")
<i>start_date<sub>i</sub></i>	ddmmyy	("010798" for July 1, 1998)
<i>start_time<sub>i</sub></i>	hhmm	(e.g. "1735" for 5:35 pm)
<i>end_date<sub>i</sub></i> (active errors)	N	(just the letter "N")
<i>end_date<sub>i</sub></i> (not active err.)	ddmmyy	("020798" for July 2, 1998)
<i>end_time<sub>i</sub></i> (active errors)	N	(just the letter "N")
<i>end_time<sub>i</sub></i> (not active err.)	hhmm	(e.g. "0920" for 9:20 am)
<i>desA<sub>i</sub></i> (errors)	N	(just the letter "N")
<i>desA<sub>i</sub></i> (setup)	P <sub>1</sub> P <sub>2</sub> C <sub>1</sub> C <sub>2</sub> C <sub>3</sub> C <sub>4</sub>	(setup item format, prev. value)
<i>desA<sub>i</sub></i> (calibration)	"XXPHX", "XOrPX", "XX ^ CX", "UOLiX"	
<i>desB<sub>i</sub></i> (errors)	N	(just the letter "N")
<i>desB<sub>i</sub></i> (setup)	P <sub>1</sub> P <sub>2</sub> C <sub>1</sub> C <sub>2</sub> C <sub>3</sub> C <sub>4</sub>	(setup item format, new value)
<i>desB<sub>i</sub></i> (calibration)	N	(just the letter "N")
<i>desB<sub>i</sub></i> (cleaning)	N	(just the letter "N")

See above in this section for the description of setup item format "P<sub>1</sub>P<sub>2</sub>C<sub>1</sub>C<sub>2</sub>C<sub>3</sub>C<sub>4</sub>".

Events are logged in the event log file in chronological order, i.e. record number 1 refers to the oldest event. When the event log file is full, the oldest event is replaced with the oncoming one.

In order to speed up the updating of a remote monitor for the events, the **NNEVF**<CR> command is supported by **NNEVN**<CR>, the new event request command, which is answered with the list of events occurred since the last reception of a **NNEVF**<CR> or **NNEVN**<CR> command.

Here is the format for answer to **NNEVN**<CR> :

"NN<STX>0<ETX>" if there is no new event, otherwise:

"NN<STX>*new\_events\_no event\_code<sub>1</sub> start\_date<sub>1</sub> start\_time<sub>1</sub> end\_date<sub>1</sub> end\_time<sub>1</sub> desA<sub>1</sub>desB<sub>1</sub>...*

*event\_code<sub>2</sub> start\_date<sub>2</sub> start\_time<sub>2</sub> end\_date<sub>2</sub> end\_time<sub>2</sub> desA<sub>2</sub>desB<sub>2</sub>...*

*event\_code<sub>m</sub> start\_date<sub>m</sub> start\_time<sub>m</sub> end\_date<sub>m</sub> end\_time<sub>m</sub>*



`desAmdesBm<ETX>`"

where *m* is the number of events. Each token is followed by a blank space, except the last one ("`desBm`"), directly followed by the `<ETX>` character.

"`new_events_no`" is the number of new events and its format is the ASCII format for a number ("1", "2".... "99", "100").

When a **NNEVF**<CR> or **NNEVN**<CR> command is received by the instrument, the new events list is reset and a following **NNEVN**<CR> command will be answered with "`NN<STX>0<ETX>`" if no event took place in the meantime. Thus, if the answer to **NNEVN**<CR> command is not received correctly, to update a remote monitor for events, the **NNEVF**<CR> command for the whole event log file must be used.

**Note** After a reset of the instrument, the answer to **NNEVN**<CR> is the same as **NNEVF**<CR> (all events are new).

**Note** A modified record due to the closing of an error is not transmitted by **NNEVN**<CR>, so again the **NNEVF**<CR> command is needed.

A small subset of the event log file, with information about the active errors, can be downloaded through the **NNAER**<CR> command. The answer is:

`"NN<STX>C1C2C3C4C5C6<ETX>`"

where *C<sub>1</sub>C<sub>2</sub>* are the ASCII representation of byte *B<sub>1</sub>* described below (e.g. *B<sub>1</sub>* = 0xF3 □ *C<sub>1</sub>* = "F", *C<sub>2</sub>* = "3"), *C<sub>3</sub>C<sub>4</sub>* are the ASCII representation of byte *B<sub>2</sub>* described below (e.g. *B<sub>2</sub>* = 0x1D □ *C<sub>3</sub>* = "1", *C<sub>4</sub>* = "D"), *C<sub>5</sub>C<sub>6</sub>* are the ASCII representation of byte *B<sub>3</sub>* described below (e.g. *B<sub>3</sub>* = 0xBE □ *C<sub>5</sub>* = "B", *C<sub>6</sub>* = "E").

The meaning of *B<sub>1</sub>*, *B<sub>2</sub>*, *B<sub>3</sub>* is:

<i>B<sub>3</sub></i> bit 0	free for future use (and set to 0)
<i>B<sub>3</sub></i> bit 1	free for future use (and set to 0)
<i>B<sub>3</sub></i> bit 2	free for future use (and set to 0)
<i>B<sub>3</sub></i> bit 3	Life check error
<i>B<sub>3</sub></i> bit 4	pH electrode broken or leakage
<i>B<sub>3</sub></i> bit 5	Reference electrode broken or leakage
<i>B<sub>3</sub></i> bit 6	Old pH probe
<i>B<sub>3</sub></i> bit 7	Dead pH probe

<i>B<sub>2</sub></i> bit 0	No calibration
<i>B<sub>2</sub></i> bit 1	Temperature probe broken
<i>B<sub>2</sub></i> bit 2	free for future use (and set to 0)
<i>B<sub>2</sub></i> bit 3	free for future use (and set to 0)
<i>B<sub>2</sub></i> bit 4	Power reset
<i>B<sub>2</sub></i> bit 5	EEPROM corruption
<i>B<sub>2</sub></i> bit 6	Watchdog reset
<i>B<sub>2</sub></i> bit 7	free for future use (and set to 0)
<i>B<sub>1</sub></i> bit 0	free for future use (and set to 0)
<i>B<sub>1</sub></i> bit 1	free for future use (and set to 0)
<i>B<sub>1</sub></i> bit 2	free for future use (and set to 0)
<i>B<sub>1</sub></i> bit 3	free for future use (and set to 0)
<i>B<sub>1</sub></i> bit 4	free for future use (and set to 0)
<i>B<sub>1</sub></i> bit 5	free for future use (and set to 0)
<i>B<sub>1</sub></i> bit 6	free for future use (and set to 0)
<i>B<sub>1</sub></i> bit 7	free for future use (and set to 0)

Each bit is equal to 1 if the correspondent error is ON and equal to 0 if the correspondent error is OFF.

**Note** When a "NAK" or "CAN" char is sent, the whole instrument reception buffer is cleared.

**Note** When the meter is receiving and answering to commands other than "PHR", "MVR", "TMR", "AER", "STS", the primary LCD of **HI 504920** (in **HI 504910** terminal mode) or the primary LCD of **HI 504910** displays "r485".

## MODEM CONNECTION

A modem connection can be established between **HI504910** and a remote computer over a telephone line. It is possible to make two different type of remote connection:

- Over the **GSM network**, connecting the **HI504900** cellular module to **HI504910** RS485 port.

To enable the modem connection with **HI504900** first it is necessary to configure the cellular phone: set item P.01 with the PIN code of the SIM card in the **HI504900** module and then set item P.00 to "CELL". To complete the configuration set item O.31 ("Modem calls answer enable") to "On".

**Note** A SIM card able to receive data calls must be used.

- Over a standard **analog telephone line**, connecting the **HI504902** modem module to **HI504910** RS485 port.

To enable the modem connection with **HI504902**, first set item P.00 to "PC", then set item O.31 to "On" and finally set item O.32 with the dialing code of the country where the instrument is installed (for example "049" for Germany or "001" for United States).

**Note** The **HI504902** modem module must be connected to **HI504910** RS485 port (not necessary to telephone line) and switched on while the previous configuration is carried out.

**Note** If the country code is shorter than 3 characters, fill the code with zeros in front (for example the country code "49" must be entered as "049" or the country code "1" must be entered as "001").

**Note** The modem present in the **HI504902** module is Telecom certified for working in all the following countries: Argentina, Australia, Austria, Belgium, Brazil, Canada, Chile, China, Cyprus, Czech Republic, Denmark, Finland, France, Germany, Greece, Hong Kong, Hungary, Iceland, India, Indonesia, Ireland, Israel, Italy, Japan, Korea, Liechtenstein, Luxembourg, Malaysia, Mexico, Netherlands, New Zealand, Norway, Philippines, Poland, Portugal, Russia, Singapore, Slovak Republic, South Africa, Spain, Sweden, Switzerland, Taiwan, Turkey, United Kingdom, United States.

If your country is not present in the list, please contact your Dealer.

The modem connection (both with **HI504900** and **HI504902**) allows the user to ask the controller from a remote position about its status, measurements and to change some parameters.

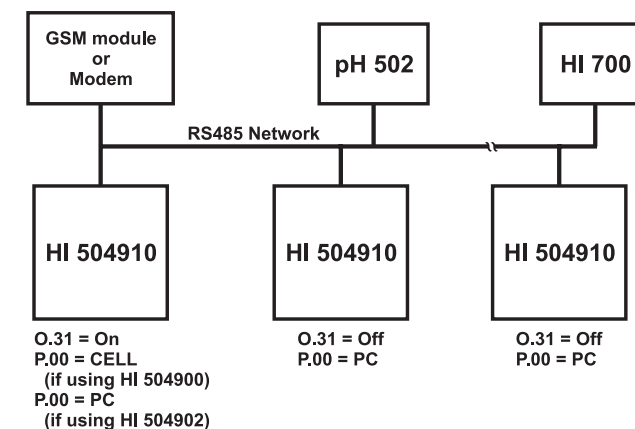

Many devices can be monitored through a remote modem connection, simply connecting all the devices and the modem or cellular module to the same RS485 network.

Only one device has to be configured through O.31 to answer to modem calls. That device will be the one controlling the modem or the cellular module. To avoid conflicts, the following must never be done:

- put more than one modem or cellular module in the same RS485 network;
- set O.31 to "On" in more than one device in the same RS485 network;
- set P.00 to "CELL" in more than one device in the same RS485 network
- set O.31 to "On" in one device and P.00 to "CELL" in another one within the same RS485 network;
- put a PC monitor within the RS485 network.

Provided the above, any Hanna instrument with RS485 port can be attached to the network and monitored remotely.

When making a call, after the data connection is established, the "NNPWD..." command (where "NN" is the address of the device controlling the modem, i.e. the one with 0.31 set to "On") must be issued by the remote computer within 15 seconds. When the data connection is up, the RS485 protocol for a remote connection is all the same as for a local network (see the previous section). An automatic disconnection takes place if no character is received in the RS485 network in 3-4 minutes.

- Note** When confirming the "CELL" option for setup item P.00, if the LCD shows a blinking "WRONG" verify if:
- the SIM card is correctly inserted;
  - the PIN number is correct;
  - the signal coverage is good.

## SELFTEST PROCEDURES

The selftest procedure can be made only entering the setup menu and selecting one of the items of the "tEst" group (t.00 - t.03).

- Note** All the tests are made while in setup mode, where a time-out is present. If no action is performed for about 5 minutes, the mode is automatically exited and the instruments returns to previous mode.

### DISPLAY TEST

The display selftest procedure consists of lighting up all the display segments together.

- To start the procedure select setup item t.00 and an "OFF" blinking message will appear on the primary LCD.
- Press the  $\square$  (or  $\square$ ) key once and the message will switch to a blinking "GO".
- Press CFM key to confirm or the  $\square$  (or  $\square$ ) key again to return to the previous status.
- If confirmation is given when the "OFF" message is blinking, no action is performed and it will move to the next setup item (t.02).
- The display test is announced by a scrolling "Display test" message.

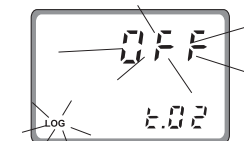
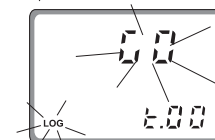
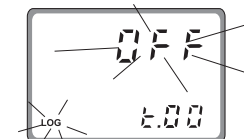

- All the segments light up for a few seconds and then switch off before exiting the display test procedure and moving to the next setup item (t.02).

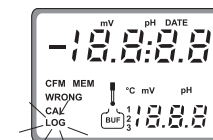

## EEPROM SELFTEST

The EEPROM selftest procedure involves verifying the stored EEPROM checksum.

- To enter the EEPROM test procedure select the setup item t.02 and an "OFF" blinking message will appear on the LCD.
- Press the  $\square$  (or  $\square$ ) key once and the message will switch to a blinking "GO".
- Press CFM key to confirm or the  $\square$  (or  $\square$ ) key again to return to the previous status.
- If confirmation is given when the "OFF" message is blinking, no action is performed and it will move to the next setup item (t.03).
- After confirmation, the selftest procedure begins with the "tEST" message blinking for a few seconds.
- During this time the instrument performs the EEPROM check, and if the checksum is correct, the "Stored data good" message will scroll on the primary display.

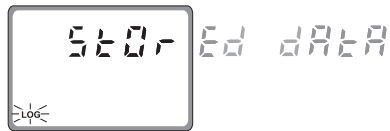
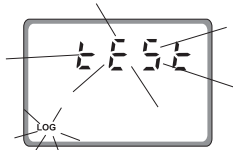

- After that, the meter will remain in setup menu and move to the next setup item.
- If the checksum fails, a fault alarm is generated and the following message appears on the LCD: "Stored data error - Press "UP" button to reset stored data or "RIGHT" button to ignore".
- If the  $\square$  key is pressed the instrument restarts operation, but the device will be in Hold mode in any case (i.e. no acquisition of measurements).
- If the  $\square$  key is pressed, all the data stored in the EEPROM are erased and the default values loaded (a complete calibration of the instrument is needed).
- Once performed the selected action, the instrument will remain in the setup menu and move to the next setup item (t.03).

## LEDs TEST

- To enter the LEDs test procedure select the setup item t.03 and an "OFF" blinking message will appear on the LCD.
- Press the  $\square$  (or  $\square$ ) key once and the message will switch to a blinking "GO".
- Press CFM key to confirm or the  $\square$  (or  $\square$ ) key again to return to the previous status.
- If confirmation is given when the "OFF" message is blinking, no action is performed and it will move to the first setup item of the group (t.00).
- Once confirmed the test, all the LEDs (if anyone was active) are switched off and the message "LEDs test - Press CFM to escape" will scroll on the primary LCD during all the test.
- Some keys are used to toggle LEDs ON and OFF:
  - the DISPLAY key toggles the green LED;
  - the (ALT+) CAL DATA keys toggle the red LED.
- To exit the test press the CFM key and the previous configuration of the LEDs is reestablished. The instrument will remain in the setup menu and move to the first setup item of the group (t.00).

## pH VALUES AT VARIOUS TEMPERATURES

Temperature has a significant effect on pH. The calibration buffer solutions are effected by temperature changes to a lesser degree than normal solutions.

For manual temperature calibration please refer to the following chart:

TEMP		pH VALUES				
°C	°F	4.01	6.86	7.01	9.18	10.01
0	32	4.01	6.98	7.13	9.46	10.32
5	41	4.00	6.95	7.10	9.39	10.24
10	50	4.00	6.92	7.07	9.33	10.18
15	59	4.00	6.90	7.04	9.27	10.12
20	68	4.00	6.88	7.03	9.22	10.06
25	77	4.01	6.86	7.01	9.18	10.01
30	86	4.02	6.85	7.00	9.14	9.96
35	95	4.03	6.84	6.99	9.10	9.92
40	104	4.04	6.84	6.98	9.07	9.88
45	113	4.05	6.83	6.98	9.04	9.85
50	122	4.06	6.83	6.98	9.01	9.82
55	131	4.07	6.84	6.98	8.99	9.79
60	140	4.09	6.84	6.98	8.97	9.77
65	149	4.11	6.85	6.99	8.95	9.76
70	158	4.12	6.85	6.99	8.93	9.75

For instance, if the buffer temperature is 25°C, the display should show pH 4.01, 7.01 or 10.01 at pH 4, 7 or 10 buffers, respectively.

At 20°C, the display should show pH 4.00, 7.03 or 10.06. The meter reading at 50°C will then be 4.06, 6.98 or 9.82.

## ELECTRODE CONDITIONING AND MAINTENANCE

### PREPARATION

Remove the electrode protective cap.

DO NOT BE ALARMED IF ANY SALT DEPOSITS ARE PRESENT.

This is normal with electrodes and they will disappear when rinsed with water.

During transport tiny bubbles of air may have formed inside the glass bulb. The electrode cannot function properly under these conditions. These bubbles can be removed by "shaking down" the electrode as you would do with a glass thermometer.

If the bulb and/or junction are dry, soak the electrode in **HI 70300 Storage Solution** for at least one hour.

If the electrode does not respond to pH changes, the battery may be run down and should be replaced.

### TEST MEASUREMENT

Rinse the electrode tip with distilled water.

Immerse the tip (bottom 4 cm / 1 1/2") in the sample and stir gently for approximately 30 seconds.

For a faster response and to avoid cross contamination of the samples, rinse the electrode tip with the solution to be tested, before taking your measurements.

### STORAGE

To minimize clogging and assure a quick response time, the glass bulb and the junction should be kept moist and not allowed to dry out. This can be achieved by installing the electrode in such a way that it is constantly in a well filled with the sample (stream or tank).

When not in use, replace the solution in the protective cap with a few drops of **HI 70300 Storage Solution** or, in its absence, **HI 7082 KCl 3.5M Solution**.

Follow the Preparation Procedure above before taking measurements.

**Note** NEVER STORE THE ELECTRODE IN DISTILLED OR DEIONIZED WATER.

## PERIODIC MAINTENANCE

Inspect the electrode and the cable. The cable used for the connection to the controller must be intact and there must be no points of broken insulation on the cable or cracks on the electrode stem or bulb.

Connectors must be perfectly clean and dry. If any scratches or cracks are present, replace the electrode. Rinse off any salt deposits with water.

## CLEANING PROCEDURE

*General* Soak in Hanna **HI 7061** General Cleaning Solution for approximately ½ hour.

Removal of films, dirt or deposits on the membrane/junction:

*Protein* Soak in Hanna **HI 7073** Protein Cleaning Solution for 15 minutes.

*Inorganic* Soak in Hanna **HI 7074** Inorganic Cleaning Solution for 15 minutes.

*Oil/grease* Rinse with Hanna **HI 7077** Oil and Fat Cleaning Solution.

### IMPORTANT

After performing any of the cleaning procedures rinse the electrode thoroughly with distilled water and soak the electrode in **HI 70300** Storage Solution for at least 1 hour before reinstalling it.

## TROUBLESHOOTING

Evaluate your electrode performance based on the following.

- Noise (Readings fluctuate up and down) could be due to clogged or dirty junction: refer to the Cleaning Procedure above.
- Dry Membrane/Junction: soak in Storage Solution **HI 70300** for at least 1 hour. Check to make sure the installation is such as to create a well for the electrode bulb to constantly remain moist.
- Drifting: soak the electrode tip in warm Hanna Solution **HI 7082** for one hour and rinse tip with distilled water.
- Low Slope: refer to the cleaning procedure above.
- No Slope:
  - Check the electrode for cracks in glass stem or bulb (replace the electrode if cracks are found).

- Make sure cable and connections are not damaged nor lying in a pool of water or solution.

- Slow Response/Excessive Drift: soak the tip in Hanna Solution **HI 7061** for 30 minutes, rinse thoroughly in distilled water and then follow the Cleaning Procedure above.
- For ORP Electrodes: polish the metal tip with a lightly abrasive paper (paying attention not to scratch the surface) and wash thoroughly with water.

### Note

With industrial applications, it is always recommended to keep at least one spare electrode handy. When anomalies are not resolved with a simple maintenance, change the electrode (and recalibrate the instrument) to see if the problem is alleviated.

## ACCESSORIES

### pH CALIBRATION SOLUTIONS

HI 7004M or HI 7004L	pH 4.01 Buffer Solution, 230 or 500 ml bottle
HI 7006M or HI 7006L	pH 6.86 Buffer Solution, 230 or 500 ml bottle
HI 7007M or HI 7007L	pH 7.01 Buffer Solution, 230 or 500 ml bottle
HI 7009M or HI 7009L	pH 9.18 Buffer Solution, 230 or 500 ml bottle
HI 7010M or HI 7010L	pH 10.01 Buffer Solution, 230 or 500 ml bottle

### ORP SOLUTIONS

HI 7020M or HI 7020L	Test Solution, 200-275 mV, 230 or 500 ml bottle
HI 7091M or HI 7091L	Pretreatment Reducing Solution, 230 or 500 ml bottle
HI 7092M or HI 7092L	Pretreatment Oxidizing Solution, 230 or 500 ml bottle

### ELECTRODE STORAGE SOLUTIONS

HI 70300M or HI 70300L	Storage Solution, 230 or 500 ml bottle
HI 7082	3.5M KCl Electrolyte, 4x50 ml

### ELECTRODE CLEANING SOLUTIONS

HI 7061M or HI 7061L	General Cleaning Solution, 230 or 500 ml bottle
HI 7073M or HI 7073L	Protein Cleaning Solution, 230 or 500 ml bottle
HI 7074M or HI 7074L	Inorganic Cleaning Solution, 230 or 500 ml bottle
HI 7077M or HI 7077L	Oil & Fat Cleaning Solution, 230 or 500 ml bottle

### OTHER ACCESSORIES

HI 504900	Hanna GSM module
HI 504902	Hanna RS485 modem
HI 504920	Remote user interface pH meter

ChecktempC	Stick Thermometer (range -50 to 150°C)
ChecktempF	Stick Thermometer (range -58 to 302°F)

HI 7610	Stainless steel Pt100 probe with standard 1/2" external threads on both ends for in-line and immersion installation; 5 m (16.5') cable
HI 7620	Glass Pt100 probe with external PG13.5 thread and 5 m (16.5') cable

HI 7611	Stainless steel Pt1000 probe with standard 1/2" external threads on both ends for in-line and immersion installation; 5 m (16.5') cable
HI 7621	Glass Pt1000 probe with external PG13.5 thread and 5 m (16.5') cable
HI 60542-0	1 set of O-rings for HI 60542 electrode holder
HI 60545-0	1 set of O-rings for HI 60545 electrode holder
HI 60501-0	1 set of O-rings for HI 60501 electrode holder
HI 605011	PVC mounting flange for HI 60501 electrode holder
HI 8427	pH / ORP Electrode Simulator
HI 931001	pH / ORP Electrode Simulator with LCD Display
HI 931002	4-20 mA Simulator
HI 8614	pH Transmitter
HI 8614L	pH Transmitter with LCD
HI 8615	ORP Transmitter
HI 8615L	ORP Transmitter with LCD
HI 92500	Windows® Compatible Application Software

**pH AND ORP ELECTRODE HOLDERS**

**HI 60542**

In-line electrode holder for direct pipe installation

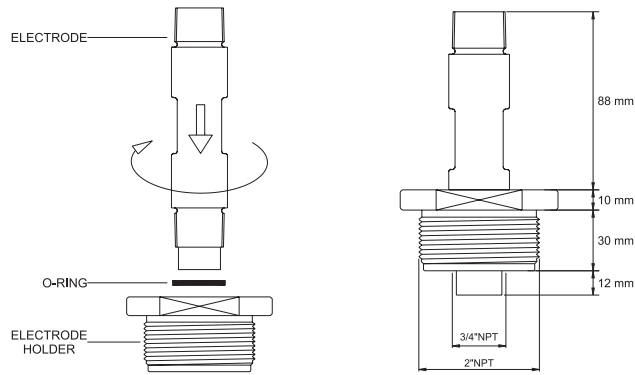

**HI 60545**

Bypass loop electrode holder

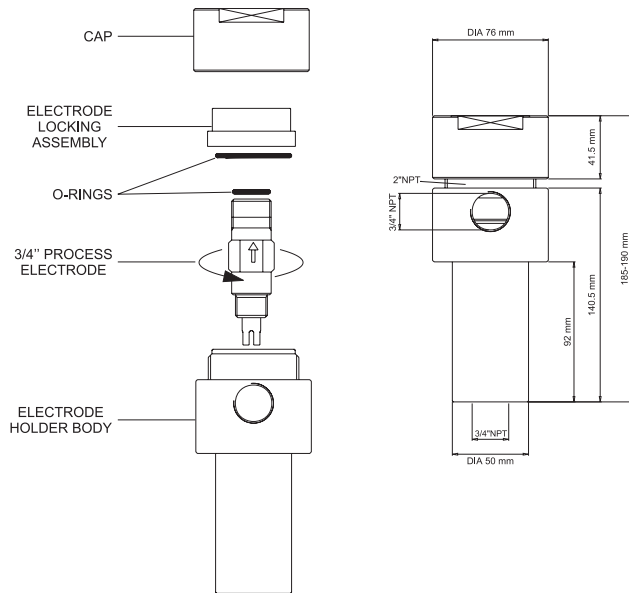

**HI 60501**

Immersion electrode holder for tanks, vessels, baths and open channels

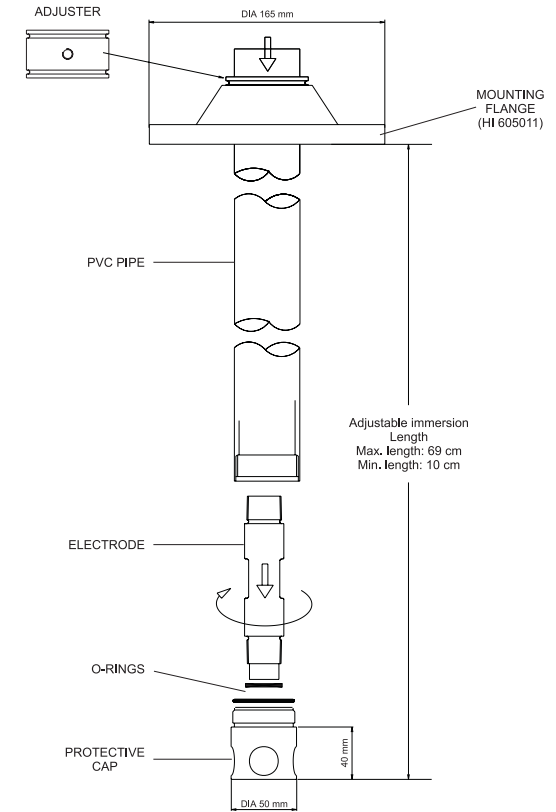

Specifications	HI 60542	HI 60545	HI 60501
Electrode Holder Material	PVC	PVC	PVC
O-Ring Material	NBR	NBR	NBR
Min. & Max. Temperature	-10°C (14°F) & 60°C (144°F)		
Min. Immersion Length	---	---	10 cm (3.9")
Max. Immersion Length	69 cm (27.1")		
Max. Pressure	8 BAR (116 PSI) @25°C or 3 BAR (43.5 PSI) @50°C		---



## pH AND ORP ELECTRODES

Hanna Instruments produces a wide range of pH and ORP electrodes specifically designed for needs of industrial uses. For a complete list of available electrodes visit our web site at [www.hannainst.com](http://www.hannainst.com) or contact your dealer.

The below table lists all the Combination, Flat tip, PVDF-body, polymer filled electrodes with Matching Pin, operating pressure: up to 6 bar (87 psi)

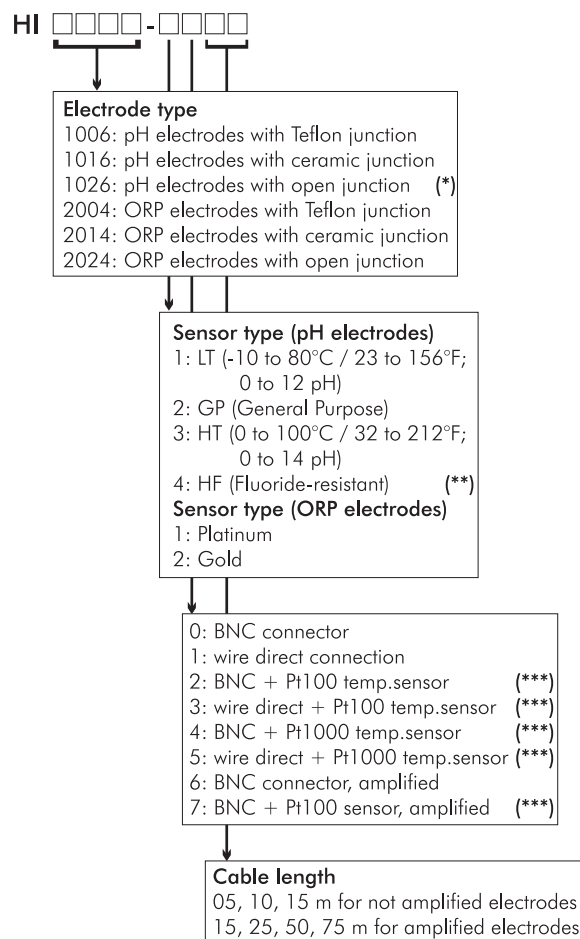



(\*) Available with GP sensor type only

(\*\*) Fluoride-resistant glass sensor ( $F < 2\text{g/L}$ , temperature  $< 60^\circ\text{C}$ ,  $\text{pH} > 2$ )

(\*\*\*) Not for ORP electrodes

## CE DECLARATION OF CONFORMITY

  

  
**DECLARATION OF CONFORMITY**

We

Hanna Instruments Italia Srl  
 via E.Fermi, 10  
 35030 Sarmeola di Rubano - PD  
 ITALY

herewith certify that the Digital Transmitter:

**HI 504910**

has been tested and found to be in compliance with EMC Directive 89/336/EEC and Low Voltage Directive 73/23/EEC according to the following applicable normatives:

**EN 50082-1:** Electromagnetic Compatibility - Generic Immunity Standard  
**IEC 61000-4-2** Electrostatic Discharge  
**IEC 61000-4-3** RF Radiated  
**IEC 61000-4-4** Fast Transient

**EN 50081-1:** Electromagnetic Compatibility - Generic Emission Standard  
**EN 55022** Radiated, Class B

**EN 61010-1:** Safety requirements for electrical equipment for measurement, control and laboratory use

Date of Issue: 18/12/2002

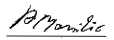
  
 A. Marsilio - Technical Director  
 On behalf of  
 Hanna Instruments S.r.l.

### Recommendations for Users

Before using this product, make sure that it is entirely suitable for the environment in which it is used.

Operation of this instrument in residential areas could cause unacceptable interferences to radio and TV equipment.

To maintain the EMC performance of equipment, the recommended cables noted in the user's manual must be used.

Any variation introduced by the user to the supplied equipment may degrade the instruments' EMC performance.

To avoid electrical shock, do not use this instrument when voltage at the measurement surface exceed 24VAC or 60VDC.

To avoid damage or burns, do not perform any measurement in microwave ovens.

External cables to be connected to the instrument should be terminated with cable lugs.

## **USER NOTES**

---

## **TECHNICAL SERVICE CONTACTS**

---

**Australia:** Tel. (03) 9769.0666 • Fax (03) 9769.0699

**China:** Tel. (10) 88570068 • Fax (10) 88570060

**Egypt:** Tel. & Fax (02) 2758.683

**Germany:** Tel. (07851) 9129-0 • Fax (07851) 9129-99

**Greece:** Tel. (210) 823.5192 • Fax (210) 884.0210

**Indonesia:** Tel. (21) 4584.2941 • Fax (21) 4584.2942

**Japan:** Tel. (03) 3258.9565 • Fax (03) 3258.9567

**Korea:** Tel. (02) 2278.5147 • Fax (02) 2264.1729

**Malaysia:** Tel. (603) 5638.9940 • Fax (603) 5638.9829

**Singapore:** Tel. 6296.7118 • Fax 6291.6906

**South Africa:** Tel. (011) 615.6076 • Fax (011) 615.8582

**Taiwan:** Tel. 886.2.2739.3014 • Fax 886.2.2739.2983

**Thailand:** Tel. 66.2619.0708 • Fax 66.2619.0061

**United Kingdom:** Tel. (01525) 850.855 • Fax (01525) 853.668

**USA:** Tel. (401) 765.7500 • Fax (401) 765.7575

*For additional Technical Support in your local language,  
see **[www.hannainst.com](http://www.hannainst.com)***