

Model 6081 Wrist Strap, Elastic, ESD

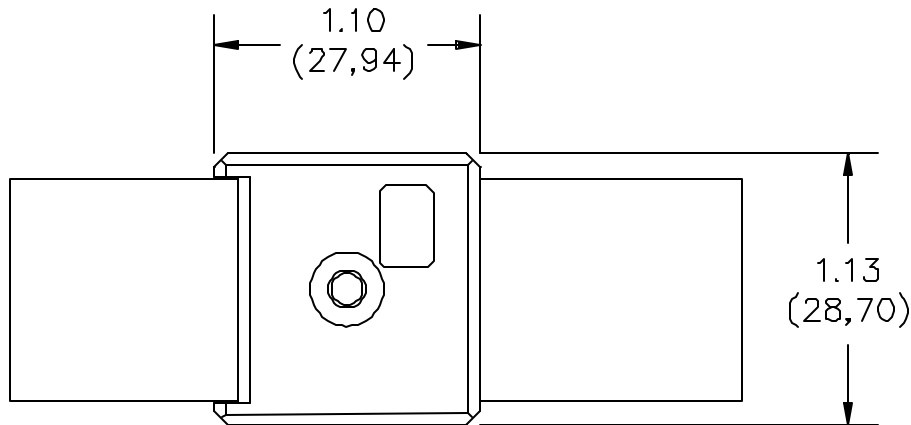

FEATURES:

- An adjustable, one size fits all, wrist strap
- The wristband features a dual stainless steel cam that securely locks the plastic band, but allows easy adjustment without tools
- The washable fabric band has silver impregnated nylon threads knitted into its inner surfaces
- Only non-allergenic stainless steel and silver touch the skin
- There is no sloughing of the conductive fibers
- A standard 4mm snap stud allows attachment to resistive coil cords

MATERIALS:

Wrist Strap

Body: Thermoplastic, Blue

Strap: Elastic fibers with silver plated nylon yarn

Circumference: 64,0 (2.50) Min., 330,0 (13.00) Max.

Snap and Cam: Stainless Steel/PVF Insulation

Width: 1.0"

ORDERING INFORMATION: Model 6081

Packaging: One Elastic Strap with Instruction Sheet per bag.

All dimensions are in inches. Tolerances (except noted): .xx = ±.02" (.51 mm), .xxx = ±.005" (.127 mm).

All specifications are to the latest revisions. Specifications are subject to change without notice.

Registered trademarks are the property of their respective companies. Made in USA