

Model 3263, 3264, 4512 Standard Banana Plug with Threaded Stud and Solder Lug

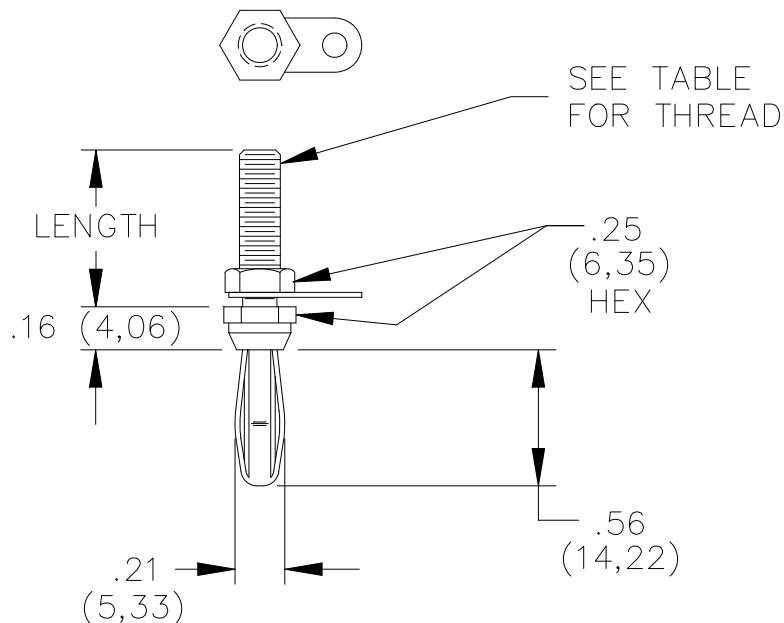
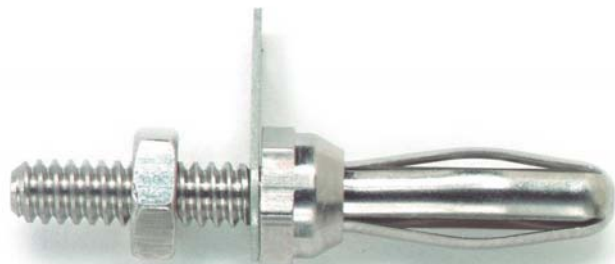

Model	Length	Thread	Torque In/Lb
3263	0.50"	6-32	7.9
3264	0.50"	8-32	7.9
4512	0.63"	8-32	7.9

Features

- Threaded stud for rapid mounting.
- Furnished with hex nut and tin plated solder lug.
- Ideal for connecting power supplies or test equipment to prototype circuit boards.
- Mates to Model #1581 or any standard banana jack.

Materials

Banana Plug:

Spring: Beryllium Copper, Berylco 25 per QQ-C-533, Cond. HT

Plug Body: Brass per QQ-B-626, Alloy 360, ½ Hard

Solder Lug:

Material: Copper per QQ-C-576

Finish: Electro-tin plated

Hex Nut:

Material: Brass per QQ-B-626, Composition 22,

½ Hard

Finish: Nickel plated

Ratings

Working Voltage: 5000 VRMS

Current: 15 Amperes

Ordering Information

Model 3263

Model 3264

Model 4512

Parts are packaged ten per bag, unassembled

USA: Sales: 800-490-2361
Technical Support: technicalsupport@pomonatest.com
Fax: 425-446-5844

Europe: 31-(0) 40 2675 150 International: 425-446-5500

Where to Buy: www.pomonaelectronics.com

All dimensions are in inches. Tolerances (except noted): .xx = ±.02" (.51 mm), .xxx = ±.005" (.127 mm). All specifications are to the latest revisions. Specifications are subject to change without notice. Registered trademarks are the property of their respective companies.