

Model 1823 Double Banana Plug Splice

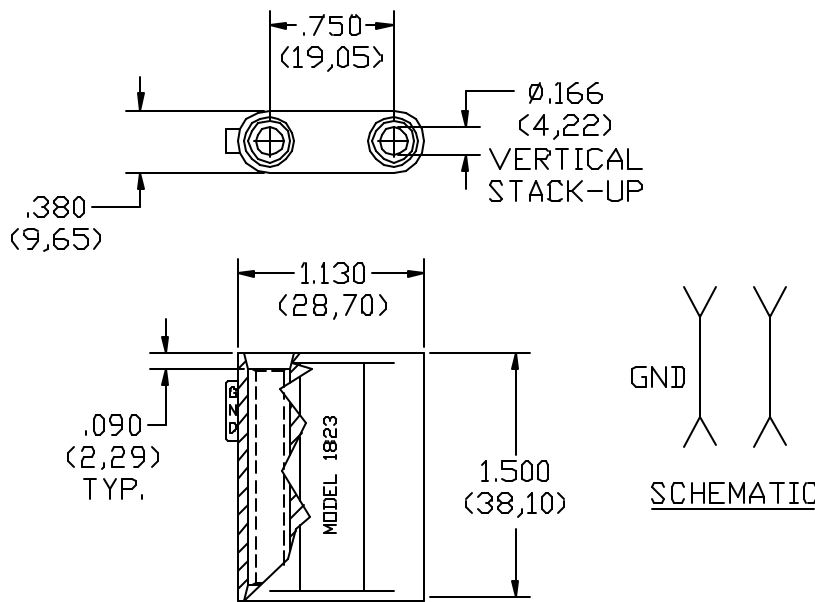

FEATURES:

- Provides rapid method for splicing cables.
- Reduces necessity of storing extra long cables.
- 4.2 (.166) dia. Banana Jacks.

MATERIALS:

Upper Conn: Double Banana Jack

Material: Brass per QQ-B-626, Alloy 360, ½ Hard.

Finish: Nickel plated per QQ-N-290, Class 2, 200 to 300 microinches.

Insulation: Polypropylene molded to Banana Jack bodies

Marking: "POMONA ELECTRONICS CALIF." "MODEL 1823."

Color: See Ordering Information

Lower Conn:

Same as Upper Conn.

RATINGS:

Operating Temperature: +55° C. (+131° F.) Max.

Operating Voltage: 5000 VDC.

Current: 15 Amperes

ORDERING INFORMATION: Model 1823-*

*= Color, -0 Black, -2 Red

Ordering Example: 1823-2 Color is Red

All dimensions are in inches. Tolerances (except noted): .xx = ±.02" (.51 mm), .xxx = ± .005" (.127 mm).

All specifications are to the latest revisions. Specifications are subject to change without notice.

Registered trademarks are the property of their respective companies. Made in USA