

# THI 350 Infrared Thermometer with Relative Humidity and Dewpoint calculation

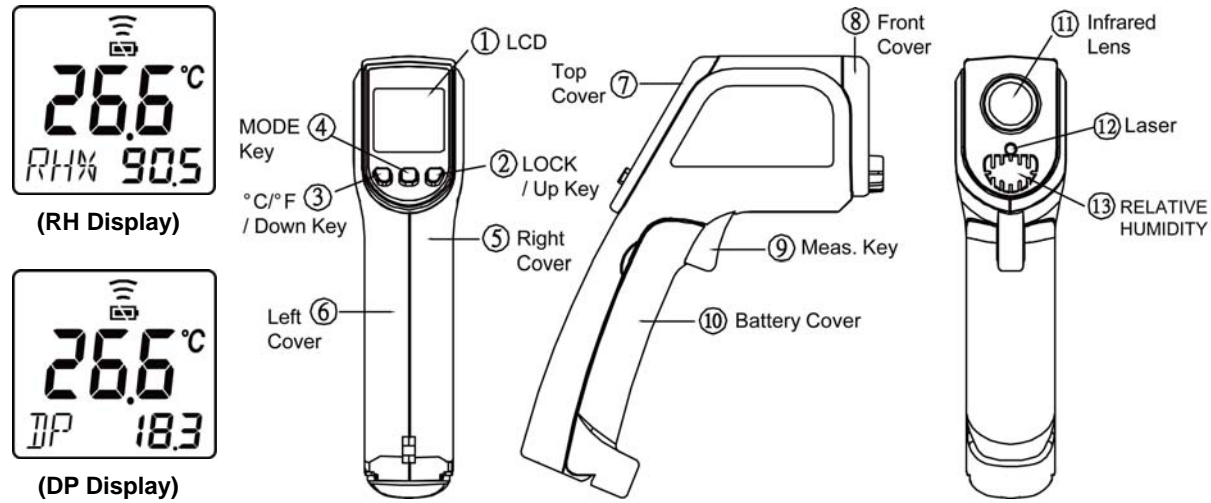

Simply aim the thermometer at the measure target with Lens (○,11) and press Meas. key (○,9) to display the surface temperature. The Distance:Spot is 12:1. Please make sure the target area is within the field of view.

## FUNCTION

Press Mode key (○,4) for scrolling more display function as follows.

	Here will show the emissivity data. (The default emissivity is 0.95.)
	Press Mode key (○,4), then press Up key (○,2) or Down key (○,3) to set the emissivity, then press Mode key (○,4) to confirm it. The emissivity can be changed from 0.10 (10E) to 1 (100E).
	Press Mode key (○,4) for the Maximum (MAX), Minimum (MIN), Different between MAX and MIN (DIF) and Average (AVG) modes. During the measurement, the special modes reading will be displayed beside the mode icon.
	Press Up key (○,2) or Down key (○,3) key to change the High Alarm (HAL) or Lo Alarm (LAL), then press Meas. key (○,9) to confirm it. For example: When the reading 26.9 °C < LAL 27 °C, the Low icon will flash and you will hear a beep sound.
	Press Mode key (○,4) for the RH and DP modes. During the measurement, the special modes reading will be displayed beside the mode icon.

\*\* The thermometer will automatically shut off if left idle for more than 60sec

## ADD VALUE

In E,MAX, MIN, DIF, AVG mode:	Press Up key (○,2) for LOCK mode ON/OFF. The lock mode is particularly useful for continuous monitoring of temperatures for up to 60 minutes. Press Down key (○,3) for °C or °F transferred.
In all modes: First hold on the Meas. key (○,9)	and press Up key (○,2) for backlight function ON/OFF. and press Down key (○,3) for laser function ON/OFF.

## CAUTION

1. WHEN DEVICE IS IN USE, DO NOT LOOK DIRECTLY INTO THE LASER BEAM-PERMANENT EYE DAMAGE MAY RESULT.
2. USE EXTREME CAUTION WHEN OPERATING THE LASER.
3. NEVER POINT THE DEVICE TOWARDS ANYONE'S EYES.

## 4. KEEP OUT OF REACH OF ALL CHILDREN.

### STORAGE & CLEANING

It should be stored at room temperature. The sensor lens is the most delicate part of the thermometer. The lens should be kept clean at all times, care should be taken when cleaning the lens using only a soft cloth or cotton swab with water or medical alcohol, allowing the lens to fully dry before using the thermometer. Do not submerge any part of the thermometer.

### LCD ERROR MESSAGES

The thermometer incorporates visual diagnostic messages as follows:

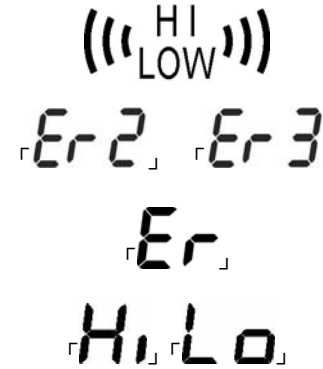

'Hi' or 'Lo' is displayed when the temperature being measured is outside of the settings of HAL and LAL.

'Er2' is displayed when the thermometer is exposed to rapid changes in the ambient temperature. 'Er3' is displayed when the ambient temperature exceeds 0°C (32°F) or +50°C (122°F). The thermometer should be allowed plenty of time (minimum 30 minutes) to stabilize to the working/room temperature.

Error 5-9, for all other error messages it is necessary to reset the thermometer. To reset it, turn the instrument off, remove the battery and wait for a minimum of one minute, reinsert the battery and turn on. If the error message remains please contact the Service Department for further assistance.

'Hi' or 'Lo' is displayed when the temperature being measured is outside of the measurement range.

### BATTERIES

The thermometer incorporates visual low battery indication as follows:



'Battery OK': measurements are possible



'Battery Low': battery needs to be replaced, measurements are still possible



'Battery Exhausted': measurements are not possible

⚠ When the 'Low Battery' icon indicates the battery is low, the battery should be replaced immediately with AAA, 1.5V batteries. Please note: It is important to turn the instrument off before replacing the battery otherwise the thermometer may malfunction.

⚠ Dispose of used battery promptly and keep away from children.

### SPECIFICATION

Item	Non-contact Infrared Scan function
Measurement Range	-60 to +500 °C (-76 to +932 °F)
Operating Range	0 to +50°C (32 to +122°F)
Accuracy (Tobj=15-35°C, Tamb=25°C)	±1.0°C (1.8°F)
Accuracy (Tobj=-33-500°C, Tamb=23±3°C)	Tobj=0-500°C: ±2% of reading or 2°C (4°F) whichever is greater
Emissivity Range	0.95 default – adjustable 0.1 to 1 step .01
Resolution (-9.9-199.9°C)	0.1°C/0.1°F
Response Time (90%)	1sec
Distance:Spot	12:1(90% energy covered)
Relative Humidity (Tamb=23+/-5degC)	1-99%, accuracy: +/-3% from 20-80%, otherwise+/-5%
Dew point	-50-50°C, accuracy: ±2.5°C from 20-30%RH; ±2°C from 31-40%RH; ±1.5°C from 41-95 %RH
Battery Life	Typ.180, min 140 hours continuous use (Alkaline, without Laser and Back Light.)
Dimensions	46.0 x 143.0 x 184.8mm(1.81x5.63x7.28 inch)
Weight	240 grams(8.5 oz) including batteries (AAA*2pcs)

Note: Under an electromagnetic field of 3V/m from 545MHz to 679 MHz the maximum error is +/- 3.5°C

⚠ EMC/RFI: Readings may be affected if the unit is operated within radio frequency electromagnetic field strength of



the performance of the instrument will not be permanently affected.